

**NOTICE TO CUSTOMER:**

**The sale of this product is intended for use of the original purchaser only and for use only on a single computer system. Duplicating, selling, or otherwise distributing this product is a violation of the law ; **your license of the product will be terminated at any moment if you are selling or distributing the products.****

No parts of this book may be reproduced, stored in a retrieval system, or transmitted, in any form or by any means, electronic, mechanical, photocopying, recording, or otherwise, without the prior written permission of the publisher.

mock papers 1

1 (a) A 12V 36W lamp is lit to normal brightness using a 12V car battery of negligible internal resistance. The lamp is switched on for one hour (3600s). For the time of 1 hour, calculate

(i) the energy supplied by the battery

energy = .....J [2]

(ii) the charge passing through the lamp

charge = .....unit.....[3]

(iii) the total number of electrons passing through the lamp.

number of electrons = ..... [2]

(b) The wires connecting the 36W lamp to the 12V battery are made of copper. They have a cross-sectional area of  $1.1 \times 10^{-7} \text{ m}^2$ . The current in the wire is 3.0A. The number  $n$  of free electrons per  $\text{m}^3$  for copper is  $8.0 \times 10^{28} \text{ m}^{-3}$ .

(i) Describe what is meant by the term *mean drift velocity* of the electrons in the wire.

.....  
.....  
..... [2]

(ii) Calculate the mean drift velocity  $v$  of the electrons in this wire.

$v = \dots\dots\dots\text{ms}^{-1}$  [3]

[Total: 12]

Turn over

2 (a) Define the *resistivity*  $\rho$  of a metal wire.

.....  
.....  
..... [2]

(b) In the UK the National Grid is used to transmit electric power. Each pylon supports 24 cables. See Fig. 2.1. Each cable consists of 38 strands of aluminium. See Fig. 2.2.

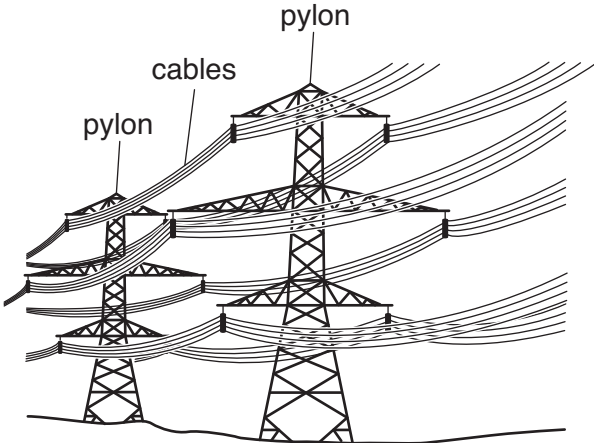

Fig. 2.1

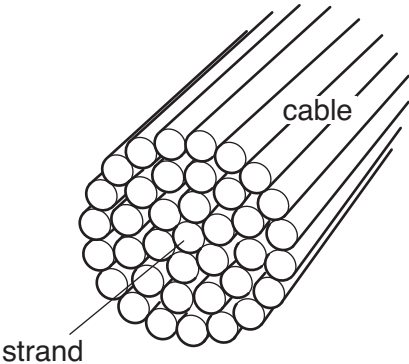

Fig. 2.2

(i) The resistance per km of a cable is  $0.052 \Omega \text{ km}^{-1}$ . Explain why the resistance per km of a single strand is approximately  $2.0 \Omega \text{ km}^{-1}$ .

.....  
.....  
..... [2]

(ii) The resistivity of aluminium is  $2.6 \times 10^{-8} \Omega \text{ m}$ . Calculate the cross-sectional area  $A$  of a single strand of the cable.

$A = \dots\dots\dots \text{m}^2$  [2]

(c) The input voltage to each cable in Fig. 2.1 is 400kV. The cable carries a current of 440A. Calculate

(i) the input power to one cable

input power = .....W [2]

(ii) the number of cables required to transmit the power from a 2000 MW power station

number of cables = .....[1]

(iii) the power lost as heat per km of cable

lost power = .....[3]

(iv) the percentage of the input power that is available at a distance of 100 km from the power station.

percentage of power = .....% [2]

[Total: 14]

Turn over

- 3 Fig. 3.1 shows a circuit containing a battery of e.m.f. 12V, two resistors, a light-dependent resistor (LDR), an ammeter and a switch **S**. The battery has negligible internal resistance.

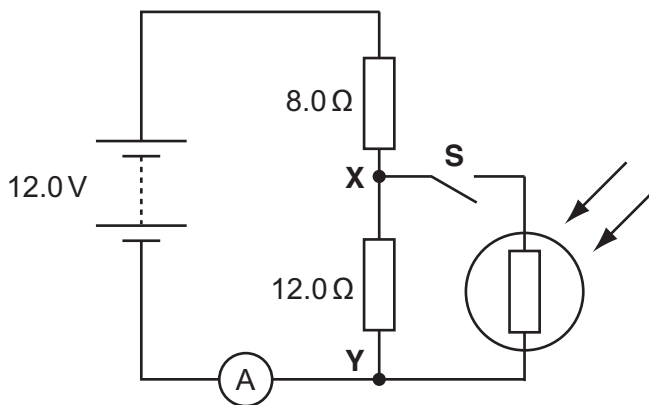

Fig. 3.1

- (a) When the switch **S** is open, show that the potential difference between the points **X** and **Y** is 7.2V.

[2]

- (b) The switch **S** is now closed. Describe and explain the change to each of the following when the intensity of light falling on the LDR is increased:

- (i) the ammeter reading

.....  
 .....  
 ..... [2]

- (ii) the potential difference across **XY**.

.....  
 .....  
 ..... [2]

[Total: 6]



(ii) Calculate the resistance of the LED

1 at 1.2V

resistance = .....  $\Omega$  [1]

2 at 1.9V.

resistance = .....  $\Omega$  [2]

(b) In order to carry out an investigation to determine the *I-V* characteristic of an LED a student connects the circuit shown in Fig. 4.2.

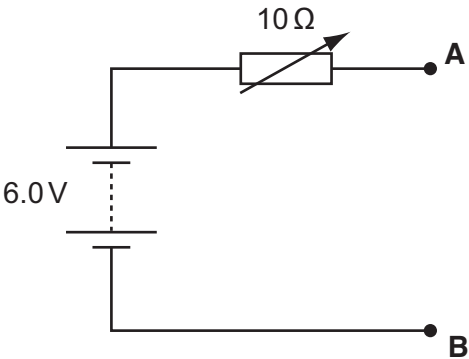

Fig. 4.2

On Fig. 4.2 add an LED with a 100  $\Omega$  resistor in series, an ammeter and a voltmeter to complete the circuit between terminals **A** and **B**. [3]

(c) When designing a circuit which includes an LED, it is normal practice to connect a resistor in series with the LED, in this case 100  $\Omega$ . Suggest and explain the purpose of this resistor.

.....

.....

..... [2]



- (d) Another student uses the  $10\ \Omega$  variable resistor as a potentiometer (potential divider) as shown in Fig. 4.3. The rest of the circuit is then completed between terminals **A** and **B** as for Fig. 4.2 in (b).

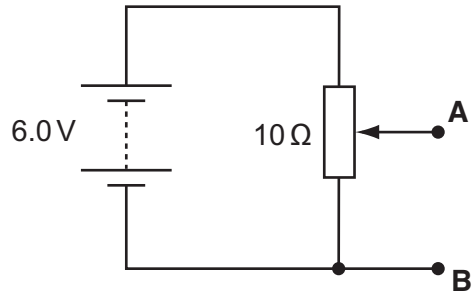

**Fig. 4.3**

Explain why the circuit of Fig. 4.3 is more suitable for obtaining the  $I$ - $V$  characteristic of the LED than the circuit of Fig. 4.2.

.....

.....

.....

.....

..... [3]

**[Total: 16]**

Turn over

- 5 (a) (i) Define the terms *wavelength*, *frequency* and *speed* used to describe a progressive wave.

*wavelength*,  $\lambda$  .....

.....

*frequency*,  $f$ .....

.....

*speed*,  $v$ .....

..... [3]

- (ii) Hence derive the wave equation  $v = f\lambda$  which relates these terms together.

[2]

- (b) (i) Explain what is meant by *infra-red radiation*.

.....

.....

..... [2]

- (ii) For infra-red radiation emitted at a frequency of  $6.7 \times 10^{13}$  Hz, calculate

- 1 its wavelength

wavelength = ..... m [2]

- 2 its period of oscillation.

period = ..... s [2]

- (iii) Infra-red radiation is absorbed by molecular ions in a crystal causing them to vibrate at a frequency of  $6.7 \times 10^{13}$  Hz. The amplitude of oscillation of the ions is  $8.0 \times 10^{-12}$  m.

On the grid of Fig. 5.1 sketch a graph showing the variation with time of the displacement of an ion.

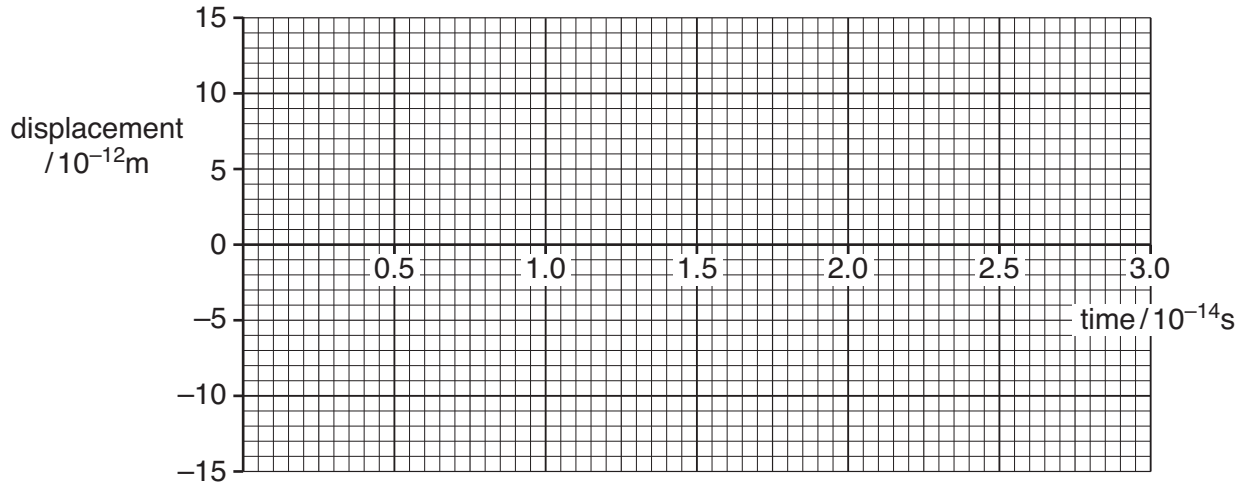

**Fig. 5.1**

[3]

[Total: 14]

Turn over

- 6 (a) Interference of waves from two sources can only be observed when the waves are coherent.

Explain the meaning of

- (i) *interference*

.....  
.....  
..... [2]

- (ii) *coherence*.

.....  
..... [1]

- (b) Fig. 6.1 shows two microwave transmitters **A** and **B** 0.20m apart. The transmitters emit microwaves of equal amplitude in phase and of wavelength 30 mm. A detector, moved along the line **PQ** at a distance of 5.0 m from **AB**, detects regions of high and low intensity forming an interference pattern.

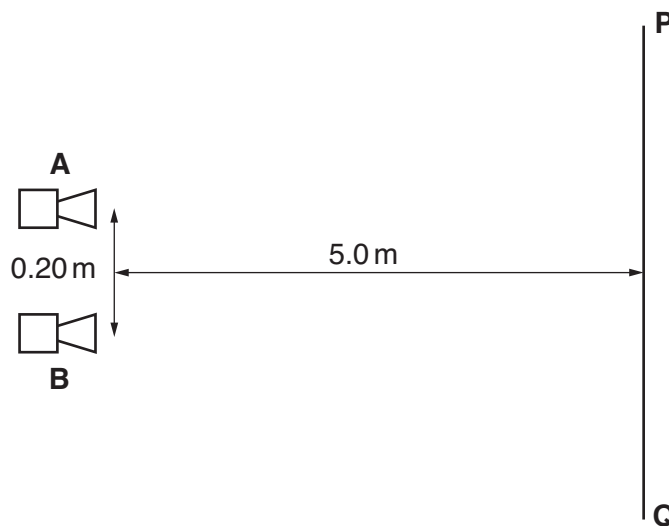

Fig. 6.1

- (i) Use the ideas of path difference or phase difference to explain how the interference pattern is formed.

.....  
.....  
.....  
.....  
.....  
..... [3]

(ii) Calculate the separation between one region of high intensity and the next along the line **PQ**.

separation = ..... m [2]

(iii) State the effect, if any, on the position and intensity of the maxima when each of the following changes is made, separately, to the experiment.

1 The amplitude of the transmitted waves is doubled.

.....  
.....  
..... [2]

2 The separation between the transmitters is halved.

.....  
.....  
..... [2]

3 The phase of transmitter **A** is reversed so that there is now a phase difference of  $180^\circ$  between the waves from **A** and **B**.

.....  
.....  
..... [2]

[Total: 14]

Turn over

7 (a) A helium-neon laser emits red light of wavelength  $6.3 \times 10^{-7}$  m.

(i) Show that the energy of a single photon is about  $3 \times 10^{-19}$  J.

[2]

(ii) The power of the laser beam is 1.0 mW. Show that about  $3 \times 10^{15}$  photons are emitted by the laser each second.

[1]

(iii) The photons of red light are emitted by the neon atoms in the gas inside the laser.

Explain what *energy levels* are and how they can be used to explain the emission of photons from atoms.



*In your answer take care to make your explanation clear.*

.....  
.....  
.....  
.....  
.....  
.....  
.....  
.....  
..... [4]

(iv) Another laser emits blue light. The power in its beam is also 1.0 mW.

Explain why the laser emitting blue light emits fewer photons per second compared with a laser of the same power emitting red light.

.....  
.....  
..... [2]

(b) A photodiode is a circuit component which can be used to convert a light signal into an electrical one. Fig. 7.1 shows an enlarged cross-section through a photodiode to illustrate how it is constructed. Light incident on the thin transparent conducting surface layer of the diode passes through it to be absorbed in the insulating layer. The energy of each photon is sufficient to release one electron in the insulating layer. The potential difference  $V$  applied across the insulating layer causes these electrons to move to one of the conducting layers.

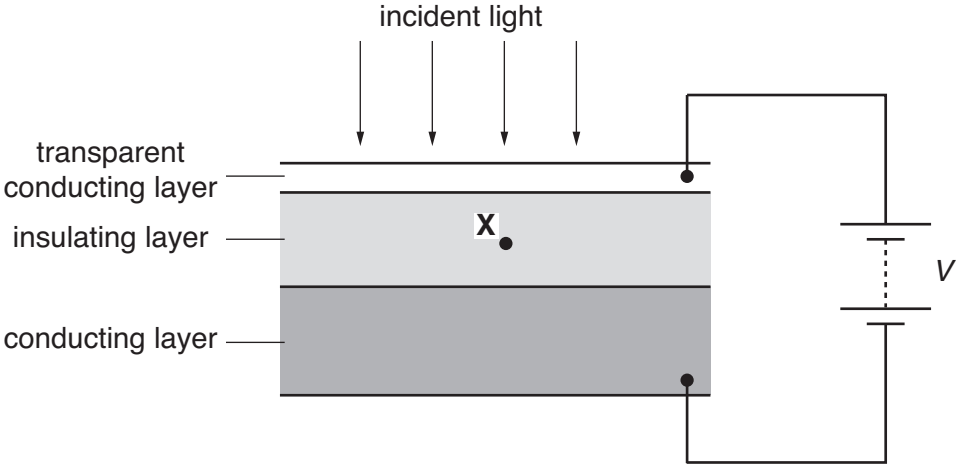

Fig. 7.1

- (i) Draw an arrow on Fig. 7.1 to show the direction of motion of an electron released at point X in the centre of the insulating layer. [1]
- (ii) The red light from the laser in (a) is incident on the photodiode. Experiments show that only 20% of the red light photons release electrons in the insulating layer and hence in the circuit of Fig. 7.1. Calculate the current through the photodiode.

current = ..... A [3]

- (iii) Suggest one reason why the efficiency of the photodiode is less than 100%.  
 .....  
 ..... [1]

[Total: 14]

Turn over

8 In 1927 it was shown by experiment that electrons can produce a diffraction pattern.

(a) (i) Explain the meaning of the term *diffraction*.

.....  
.....  
..... [1]

(ii) State the condition necessary for electrons to produce observable diffraction when passing through matter, e.g. a thin sheet of graphite in an evacuated chamber.

.....  
.....  
.....  
..... [2]

(b) Show that the speed of an electron with a de Broglie wavelength of  $1.2 \times 10^{-10}$  m is  $6.0 \times 10^6$  m s<sup>-1</sup>.

[3]



- (c) The electrons in (b) are accelerated to a speed of  $6.0 \times 10^6 \text{ ms}^{-1}$  using an electron gun shown diagrammatically in Fig. 8.1.

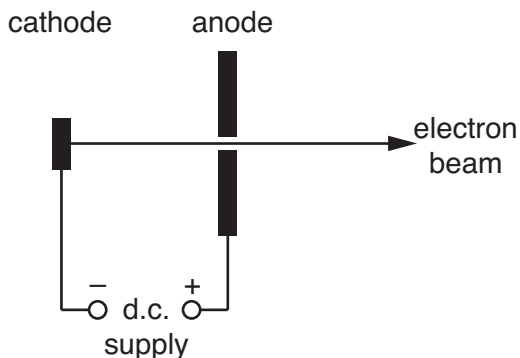

Fig. 8.1

- (i) Calculate the potential difference  $V$  across the d.c. supply between the cathode and the anode.

$V = \dots\dots\dots \text{ V [3]}$

- (ii) Suggest why, in an electron gun, the cathode is connected to the negative terminal of the supply rather than the positive terminal.

.....  
.....  
..... [1]

[Total: 10]

END OF QUESTION PAPER

- 1 A resistor **X** is constructed from a rod of cross-sectional area  $9.0 \times 10^{-6} \text{ m}^2$  and length  $0.012 \text{ m}$  as shown in Fig. 1.1. The resistivity of the material of the rod is  $2.4 \Omega \text{ m}$ .

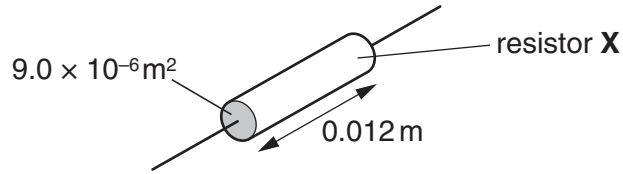

Fig. 1.1

- (a) Show that the resistance of the resistor **X** is  $3.2 \text{ k}\Omega$ .

[2]

- (b) The power rating of resistor **X** is  $0.125 \text{ W}$ . Show that the maximum potential difference which should be applied safely across the resistor is  $20 \text{ V}$ .

[2]

- (c) A student needs a resistor of the same resistance as **X** but with a power rating of  $0.50 \text{ W}$ . The only resistors available are identical to **X**. It is suggested that four of these resistors could be connected as shown in Fig. 1.2 to solve the problem. The potential difference across the combination of resistors is  $40 \text{ V}$ .

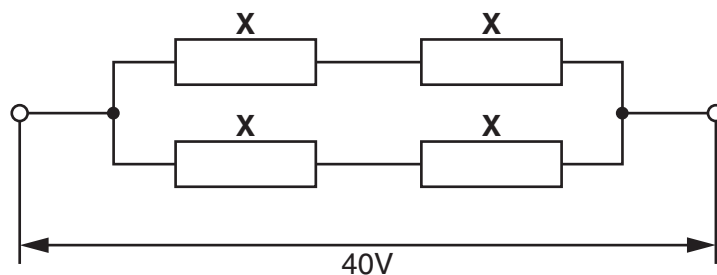

Fig. 1.2

(i) Show that the total resistance of the combination in Fig. 1.2 is 3.2 kΩ.

[2]

(ii) Show that the power dissipation in each resistor is 0.125W.

.....  
.....  
.....  
..... [2]

(d) Another resistor Y is constructed from the same material but has twice the length and twice the diameter of resistor X.

(i) Show that the resistance  $R_Y$  of Y is half the resistance  $R_X$  of resistor X.

[2]

(ii) The two resistors X and Y, where  $R_Y = R_X/2$ , are connected in series to a d.c. power supply as shown in Fig. 1.3.

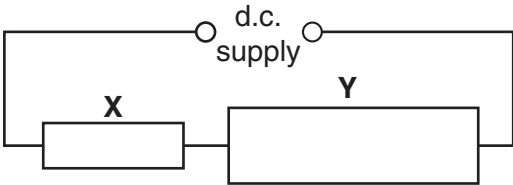

Fig. 1.3

State and explain which resistor dissipates greater power.

.....  
.....  
.....  
.....  
..... [3]

[Total: 13]

Turn over

- 2 (a) A 12V car battery contains an electrolyte. The battery is connected to an electric motor M. There is a current in the motor and the battery. See Fig. 2.1.

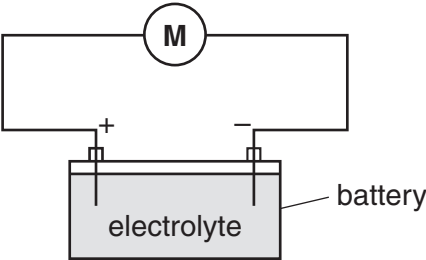

Fig. 2.1

State

- (i) the charge carriers in the electrolyte  
..... [1]
- (ii) the charge carriers moving through the electrolyte to the positive terminal of the battery  
..... [1]
- (iii) the charge carriers moving through the wires to the positive terminal of the battery.  
..... [1]

- (b) When used to start the engine of the car, the electric motor draws 40A from the battery of e.m.f. 12V. The potential difference across the motor at this time is only 8.0V.

- (i) Explain why the potential difference across the motor at this time is not the same as the e.m.f. of the car battery.  
.....  
.....  
.....  
..... [2]

- (ii) Show that the internal resistance of the battery is 0.10Ω.

[3]

(iii) It takes 1.2s for the electric motor to start the engine. Calculate the charge  $Q$  which passes through the electric motor in this time.

$Q = \dots\dots\dots C$  [2]

(c) The car has two 12V headlamps each rated at 54W, connected in parallel to the battery. In normal working conditions the current in each lamp is 4.5A.

(i) Explain how and why the resistance of the headlamp filament varies with the current passing through it.

.....  
.....  
.....  
.....  
..... [2]

(ii) Suggest a value for the current rating of a fuse for the headlamp circuit. Justify your choice.

.....  
.....  
..... [2]

(iii) A car contains a number of different fuses for its various electrical circuits. Suggest why this is necessary.

.....  
.....  
..... [1]

[Total: 15]

Turn over

3 (a) The following electrical quantities are often used when analysing circuits. Draw a straight line from each quantity on the left-hand side to its correct units on the right-hand side.

potential difference	$Cs^{-1}$
resistance	$JC^{-1}$
power	$VA^{-1}$
current	$Js^{-1}$

[3]

(b) Fig. 3.1 shows a battery of e.m.f. 6.0V and negligible internal resistance connected in series with a thermistor and a  $560\Omega$  resistor.

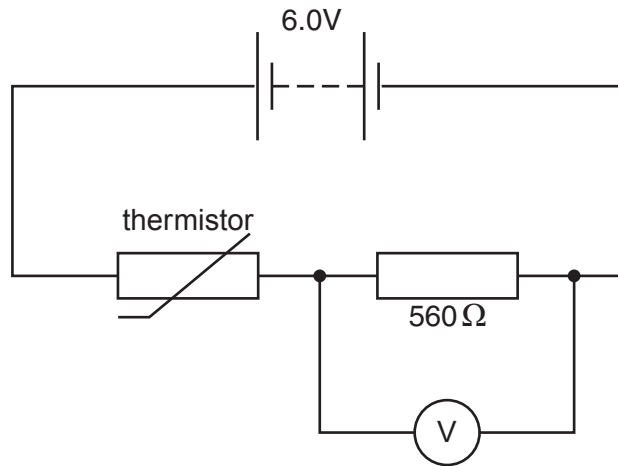

Fig. 3.1

The voltmeter across the resistor has infinite resistance.

(i) The reading on the voltmeter is 2.4V. Calculate the resistance  $R_T$  of the thermistor.

$R_T = \dots\dots\dots \Omega$  [3]

(ii) Calculate the current in the circuit.

current =  $\dots\dots\dots$  A [1]

(c) The variation of resistance with temperature for this thermistor is shown in the graph of Fig. 3.2.

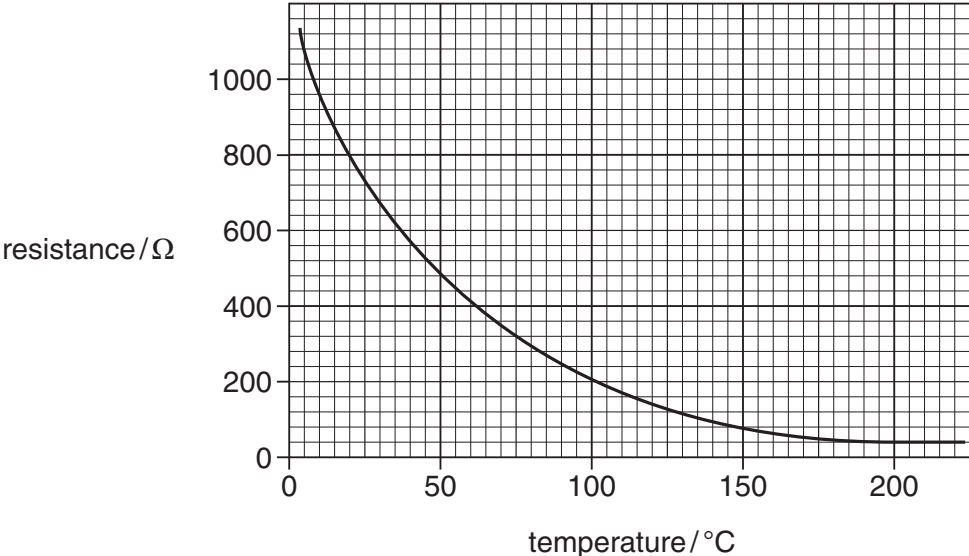

Fig. 3.2

(i) Use the graph to determine the temperature of the thermistor when its resistance is 800 Ω.

temperature = ..... °C [1]

(ii) State and explain, without calculation, how the reading of the voltmeter in Fig. 3.1 will change as the temperature of the thermistor increases to 80 °C.

.....  
.....  
.....  
.....  
..... [3]

Turn over

(iii) The circuit of Fig. 3.1 can be used as a temperature sensor. Temperature sensors are used in the kitchen to control the internal temperatures of ovens (typically 200 °C) and refrigerators (typically 4 °C). Use the graph of Fig. 3.2 to suggest in which device this sensor would be more suitable.



*In your answer you should link the information from the graph to the working of the sensor.*

.....

.....

.....

.....

..... [3]

**[Total: 14]**



- 4 Fig. 4.1 shows the variation with time  $t$  of the displacements  $x_S$  and  $x_T$  at a point **P** of two sound waves **S** and **T**.

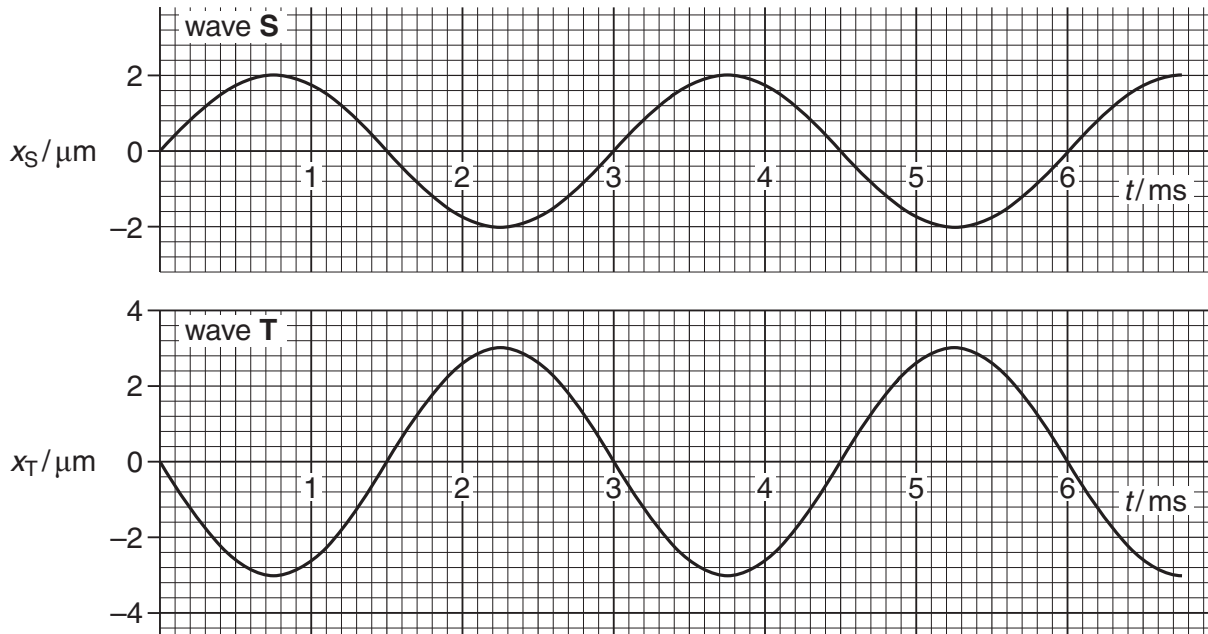

Fig. 4.1

- (a) By reference to Fig. 4.1, state one similarity and one difference between these two waves.

similarity .....

difference ..... [2]

- (b) Explain whether or not the two waves are coherent.

.....

.....

..... [2]

- (c) The speed of the sound waves is  $340 \text{ m s}^{-1}$ . Determine the frequency of wave **S** and hence its wavelength.

frequency = ..... Hz

wavelength = ..... m [4]

Turn over

(d) At point **P** the two sound waves superpose (combine). By reference to Fig. 4.1 determine the resultant displacement  $x$  of the two waves at time

(i)  $t_1 = 1.5 \text{ ms}$

$x_1 = \dots\dots\dots \mu\text{m}$  [1]

(ii)  $t_2 = 2.25 \text{ ms}$ .

$x_2 = \dots\dots\dots \mu\text{m}$  [1]

(e) The intensity of wave **S** alone at point **P** is  $I$ .

(i) Show that the intensity of wave **T** alone at point **P** is  $2.25I$ .

[2]

(ii) Calculate the intensity of the resultant wave at point **P** in terms of  $I$ .

intensity =  $\dots\dots\dots I$  [2]

(f) The sound waves shown in Fig. 4.1 are emitted from the loudspeakers labelled **S** and **T** in Fig. 4.2 and detected by the microphone at point **P**.



Fig. 4.2

(i) Calculate the distance that loudspeaker **S** must be moved towards **P** to bring the two waves into phase at **P**. State your reasoning clearly.

distance = ..... m [2]

(ii) Describe how the intensity of the sound wave detected at **P** varies as loudspeaker **S** is moved as in (i).

.....  
.....  
..... [2]

[Total: 18]

Turn over

5 (a) Kirchhoff's first and second laws can be used to analyse any electrical circuit. They are a consequence of the conservation of physical quantities in the circuit.

(i) State Kirchhoff's **first** law and the physical quantity conserved.

.....  
.....  
..... [2]

(ii) State Kirchhoff's **second** law and the physical quantity conserved.

.....  
.....  
.....  
..... [2]

(b) A physical quantity is also conserved in the photoelectric effect. Describe and explain the photoelectric effect.



*In your answer you should link the description to the conservation of this quantity.*

.....  
.....  
.....  
.....  
.....  
.....  
.....  
.....  
.....  
.....  
.....  
.....  
.....  
.....  
.....  
.....  
.....  
.....  
.....  
.....  
..... [6]

[Total: 10]

6 (a) In atomic physics electron energies are often stated in *electronvolts* (eV).

Define the *electronvolt*. State its value in joule.

.....  
.....  
..... [2]

(b) An electron is accelerated from rest through a potential difference of 300V.

(i) Calculate the final kinetic energy of the electron

1 in eV

kinetic energy = ..... eV [1]

2 in J.

kinetic energy = ..... J [1]

(ii) Show that the final speed of the electron is about  $1 \times 10^7 \text{ ms}^{-1}$ .

[2]

(c) (i) Explain what is meant by the *de Broglie wavelength* of an electron.

.....  
.....  
..... [2]

(ii) Calculate the de Broglie wavelength of the electron in (b).

wavelength = ..... m [2]

[Total: 10]  
Turn over

7 The tungsten filament of a 12V 24W lamp glows white hot emitting photons across a continuous spectrum of energies. The intensity variation with wavelength of the electromagnetic radiation from the filament is shown in Fig. 7.1.

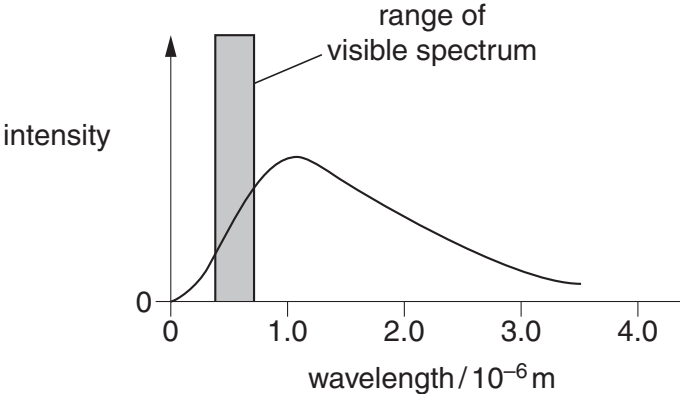

Fig. 7.1

(a) Explain what is meant by

(i) a photon

.....  
..... [1]

(ii) a continuous spectrum.

.....  
..... [1]

(b) (i) Fig. 7.1 shows that only a small percentage of the energy radiated from the filament lamp is emitted in the visible region. The majority of the energy is emitted in other regions of the electromagnetic spectrum.

1 State the region of the spectrum in which most of the radiation from the lamp is emitted.  
..... [1]

2 State a simple observation which is evidence for your answer to 1.  
.....  
..... [1]

- (ii) The 12V filament lamp emits 24W of power as electromagnetic waves. Only 5.0% of this power is converted into photons of visible light of average energy  $4.0 \times 10^{-19}$  J.

Estimate the number of these visible photons emitted from the filament per second.

number = .....  $s^{-1}$  [3]

- (c) The light from the filament is viewed through a diffraction grating, having 300 lines per millimetre. The continuous first order spectrum appears between angles  $\theta$  of  $7^\circ$  and  $12^\circ$  to the direction of the incident light. See Fig. 7.2.

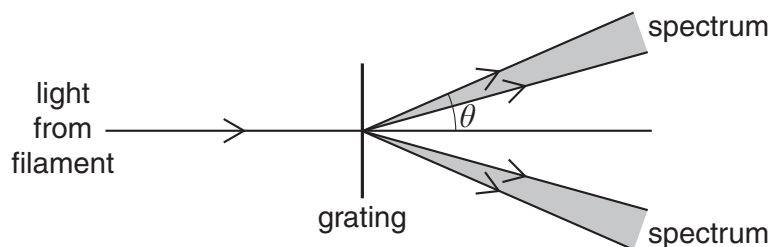

Fig. 7.2

- (i) State the colour of the light that is seen at the angle of

$7^\circ$  .....

$12^\circ$  .....

[2]

- (ii) Calculate the angle at which green light of wavelength  $5.4 \times 10^{-7}$  m is observed in this first order spectrum.

angle = .....  $^\circ$  [3]

[Total: 12]

Turn over

8 Fig. 8.1 shows some energy levels of the hydrogen atom. The diagram is not to scale.

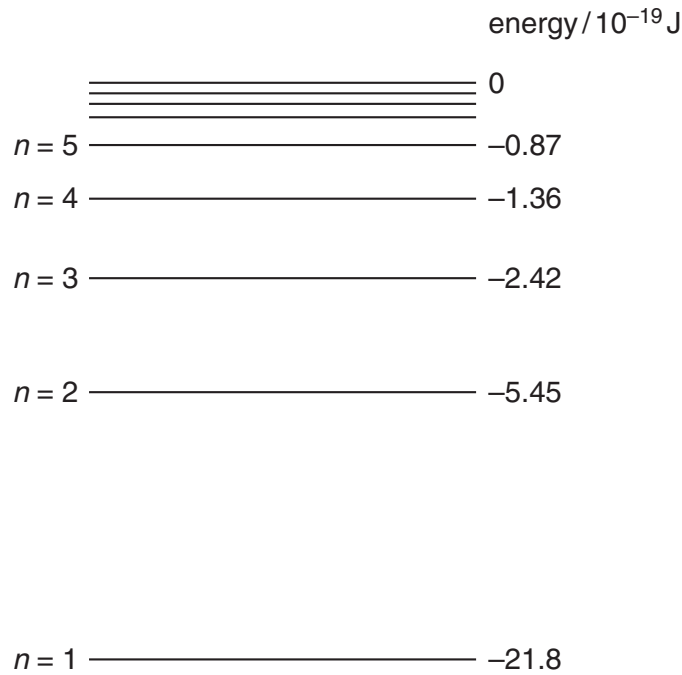

Fig. 8.1

The energy level corresponding to the lowest energy (ground) state of the atom is  $n = 1$ .

The hydrogen atom is ionised when it absorbs sufficient energy for the electron to escape from the proton; that is, for the energy labelled on Fig. 8.1 to become zero or positive.

- (a) (i) Draw an arrowed line on Fig. 8.1 to indicate the process of ionisation of an atom initially in its ground state. [1]
- (ii) Write down the value of the minimum energy required to ionise an atom in its ground state.

minimum energy = ..... J [1]

- (b) (i) Show that the energy change between levels required for the emission of a photon of wavelength 490 nm is about  $4 \times 10^{-19}$  J.

[2]





- 1 This question is about the rigid copper bars which carry the very large currents generated in a power station to the transformers. Fig. 1.1 shows such a copper bar.

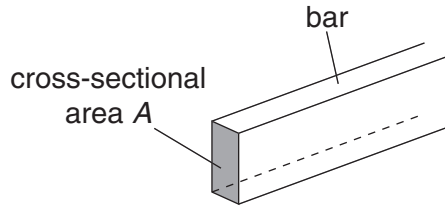

Fig. 1.1

- (a) Write down a suitable word equation to define the *resistivity* of a material.

.....  
.....  
..... [1]

- (b) (i) The cross-sectional area  $A$  of the bar is  $6.4 \times 10^{-3} \text{ m}^2$ . Calculate the resistance of a 1.0 m length of the bar. The resistivity of copper is  $1.7 \times 10^{-8} \Omega \text{ m}$ .

resistance = .....  $\Omega$  [2]

- (ii) The bar carries a constant current of 8000 A. Calculate the power dissipated as heat along a 1.0 m length of it.

power = ..... W [3]

(iii) The bar is 9.0 m long. Estimate the total energy in kW h lost from the bar in one day.

energy = ..... kW h [2]

(iv) Calculate the cost per day of operating the copper bar. The cost of 1 kW h is 15p.

cost = ..... p [1]

(c) Calculate the mean drift velocity  $v$  of the free electrons in the copper bar. The number of free electrons per unit volume in copper is  $8.4 \times 10^{28} \text{ m}^{-3}$ .

$v = \dots\dots\dots \text{ m s}^{-1}$  [3]

**[Total: 12]**

Turn over

2 (a) Fig. 2.1 shows combinations of resistors connected to a power supply of e.m.f.  $E$ .

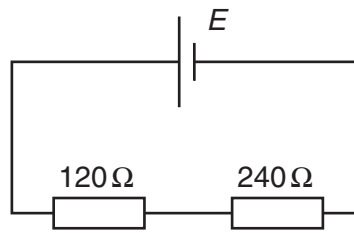

Fig. 2.1a

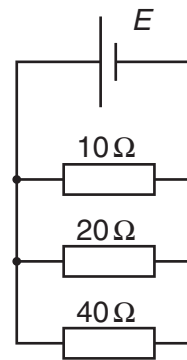

Fig. 2.1b

(i) For the circuit of Fig. 2.1a

1 calculate the total resistance  $R_s$

$R_s = \dots\dots\dots\ \Omega$  [1]

2 state one electrical quantity which is the same for both resistors.

$\dots\dots\dots$  [1]

(ii) For the circuit of Fig. 2.1b

1 calculate the total resistance  $R_p$

$R_p = \dots\dots\dots\ \Omega$  [2]

2 state one electrical quantity which is the same for all the resistors.

$\dots\dots\dots$  [1]

Turn over

- (b) Fig. 2.2 shows the  $I-V$  characteristics of two electrical components, a resistor, line **R** and a thermistor, line **T**.

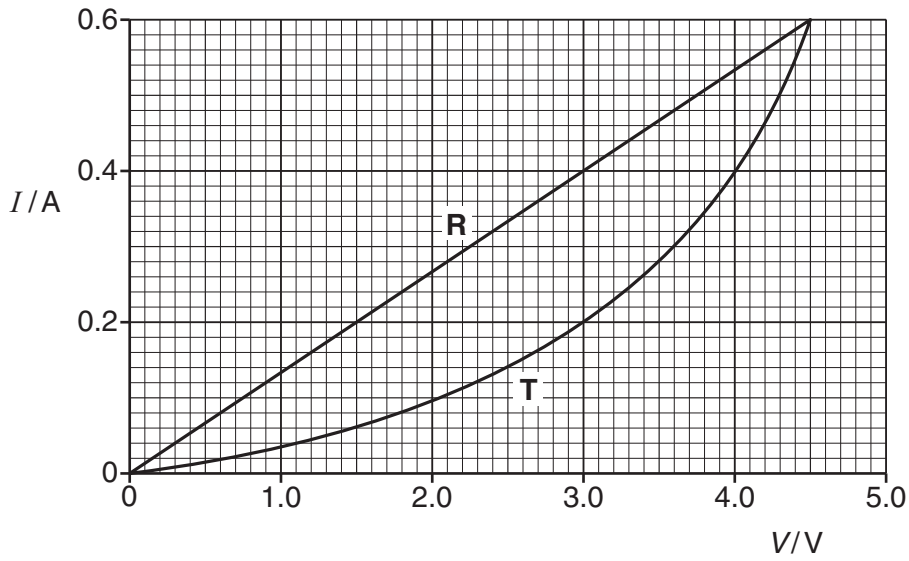

Fig. 2.2

- (i) State Ohm's law. Use Fig. 2.2 to explain why component **R** obeys Ohm's law.

.....

.....

.....

.....

.....

..... [3]

- (ii) The resistor and the thermistor can be connected to a variable voltage supply of negligible internal resistance in two ways as shown in Fig. 2.3a and Fig. 2.3b.

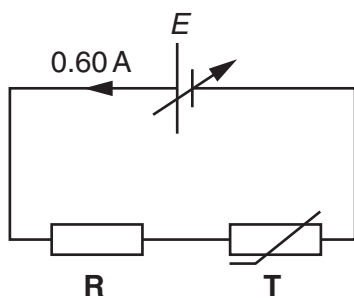

Fig. 2.3a

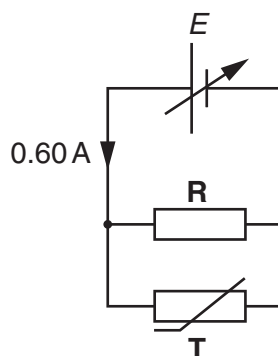

Fig. 2.3b

The voltage of the supply is varied in each circuit until the current drawn from it is 0.60 A. Use data from Fig. 2.2 to explain why the e.m.f.  $E$  of the supply is

1 9.0V in Fig. 2.3a

.....  
.....  
..... [2]

2 3.0V in Fig. 2.3b.

.....  
.....  
..... [2]

(iii) The thermistor is now connected on its own across the terminals of the supply set at 4.5V. Fig. 2.4 shows the variation of current  $I$  with time  $t$  from the moment the thermistor is connected to the supply.

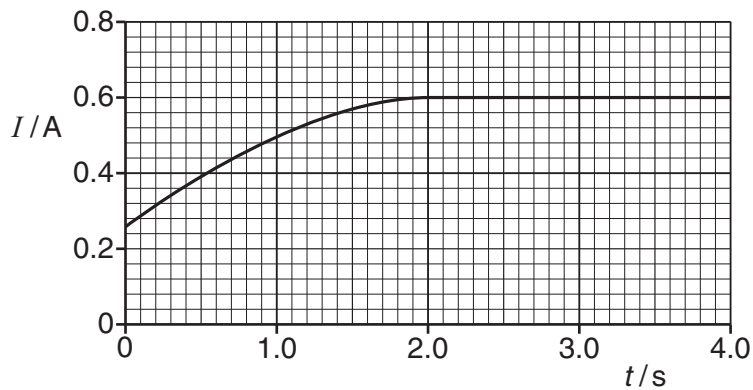

Fig. 2.4

Explain the shape of the graph in Fig. 2.4.

.....  
.....  
.....  
.....  
.....  
.....  
.....  
.....  
..... [3]

[Total: 15]  
Turn over

3 A cell is a source of e.m.f. When the cell is connected into a circuit the potential difference measured between its terminals, called the *terminal p.d.*, is less than its e.m.f.

(a) (i) Define the term *e.m.f.*

.....  
.....  
..... [2]

(ii) Explain why the terminal p.d. is less than the e.m.f.

.....  
.....  
..... [2]

(b) In the circuit of Fig. 3.1 the cell of e.m.f. 1.6V and internal resistance  $r$  is delivering a current of 0.20 A to a resistor of resistance  $R$ . The voltmeter reads the terminal p.d. It is 1.2V.

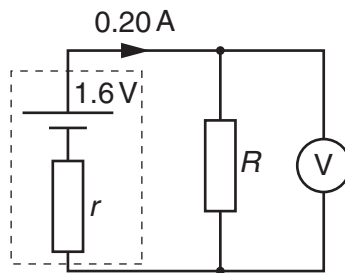

Fig. 3.1

Calculate the values of

(i) the resistance  $R$

$R = \dots\dots\dots \Omega$  [2]

(ii) the internal resistance  $r$ .

$r = \dots\dots\dots \Omega$  [2]

(c) (i) The current in the resistor of Fig. 3.1 remains constant at 0.20A for several hours. Calculate

1 the charge which passes through the resistor in 1.5 hours

charge = ..... unit ..... [3]

2 the energy dissipated by the resistor in 1.5 hours.

energy = ..... J [2]

(ii) The cell is left connected to the resistor for 12 hours. The graph of Fig. 3.2 shows the variation of current  $I$  with time  $t$ .

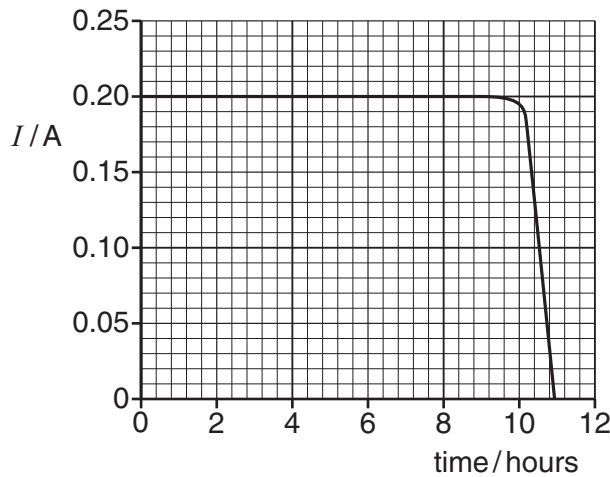

Fig. 3.2

Describe how the current varies with time. Suggest reasons why it varies in this way.



*In your answer you should link each feature of the graph to the reason for it.*

.....

.....

.....

.....

.....

.....

.....

.....

.....

.....

.....

[4]

[Total: 17]

Turn over



4 (a) Explain what is meant by a *progressive wave*.

.....  
.....  
.....  
..... [2]

(b) Describe how a *transverse wave* differs from a *longitudinal wave*.

.....  
.....  
.....  
..... [2]

(c) (i) Explain what is meant by *diffraction* of a wave.

.....  
.....  
..... [1]

(ii) Describe how you would demonstrate that a sound wave of wavelength 0.10m emitted from a loudspeaker can be diffracted.



*In your answer you should make clear how your observations show that diffraction is occurring.*

.....  
.....  
.....  
.....  
.....  
.....  
.....  
..... [4]

Turn over

(d) Fig. 4.1 shows two loudspeakers connected to a signal generator, set to a frequency of 1.2 kHz. A person walks in the direction P to Q at a distance of 3.0 m from the loudspeakers.

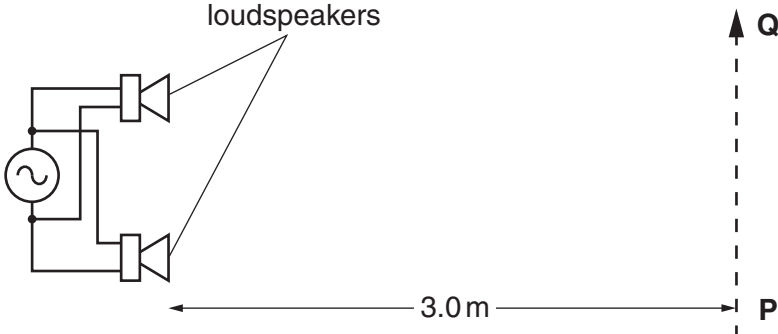

Fig. 4.1

- (i) Calculate the wavelength  $\lambda$  of the sound waves emitted from the loudspeakers.  
speed of sound in air =  $340 \text{ m s}^{-1}$

$\lambda = \dots\dots\dots \text{ m [2]}$

- (ii) Explain, either in terms of path difference or phase difference, why the intensity of the sound heard varies as the person moves along PQ.

.....  
.....  
.....  
.....  
.....  
.....  
.....  
.....  
.....  
.....  
.....  
.....  
.....  
.....  
.....  
.....  
.....  
.....  
.....  
.....  
..... [3]

(iii) The distance  $x$  between adjacent positions of maximum sound is 0.50m. Calculate the separation  $a$  between the loudspeakers. Assume that the equation used for the interference of light also applies to sound.

$a = \dots\dots\dots$  m [2]

(iv) The connections to one of the loudspeakers are reversed. Describe the similarities and differences in what the person hears.

.....  
.....  
.....  
.....  
.....  
..... [2]

[Total: 18]

Turn over

5 Fig. 5.1 shows a uniform string which is kept under tension between a clamp and a pulley. The frequency of the mechanical oscillator close to one end is varied so that a stationary wave is set up on the string.

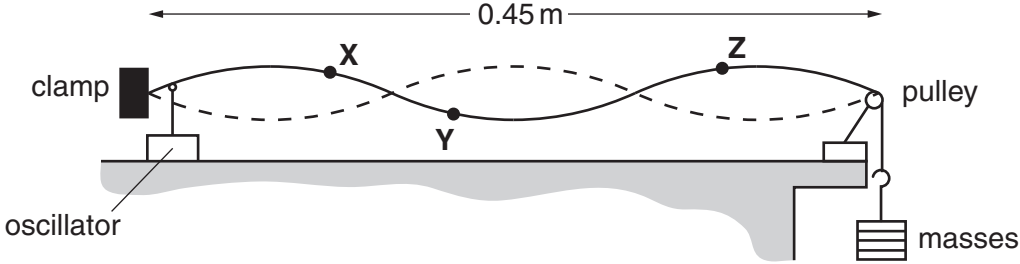

Fig. 5.1

(a) State two features of a stationary wave.

.....

.....

.....

..... [2]

(b) Explain how the stationary wave is formed on the string.

.....

.....

.....

.....

..... [2]

(c) The distance between the clamp and the pulley is 0.45 m. X, Y and Z are three points on the string. X and Y are each 0.040 m from the nearest node and Z is 0.090 m from the pulley. State, giving a reason for your choice, which of the points Y or Z or both oscillate

(i) with the same amplitude as X

.....

.....

.....

..... [2]

(ii) with the same frequency as **X**

.....  
.....  
.....  
..... [2]

(iii) in phase with **X**.

.....  
.....  
.....  
..... [2]

[Total: 10]

Turn over

6 (a) X-rays and radio waves are two examples of electromagnetic waves.

(i) Name **two** other examples of electromagnetic waves.

.....  
..... [1]

(ii) State **one** similarity and **one** difference between X-rays and radio waves.

similarity .....  
.....  
.....

difference .....  
.....  
..... [2]

(iii) Explain why X-rays are easily diffracted by layers of atoms, about  $2 \times 10^{-10}$  m apart, but radio waves are not.

.....  
.....  
.....  
..... [2]

(b) On the Earth, we are all exposed to ultraviolet radiation coming from the Sun. State **one** advantage and **one** disadvantage of UV-B radiation.

.....  
.....  
.....  
..... [2]

(c) (i) Circle a typical value for the wavelength of an X-ray from the list below.

- $2 \times 10^{-4}$  m       $2 \times 10^{-7}$  m       $2 \times 10^{-10}$  m       $2 \times 10^{-13}$  m      [1]

- (ii) Use your answer to (i) to determine how many X-ray photons must be collected to produce an energy of  $1.0 \times 10^{-6} \text{ J}$ .

number of photons = ..... [4]

- (d) A plane polarised radio wave is transmitted from a vertical aerial to a nearby receiving aerial as shown in Fig. 6.1.

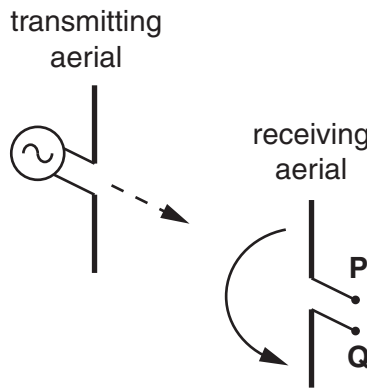

Fig. 6.1

A diode, resistor and ammeter are connected in series across the terminals **P** and **Q**.

- (i) Draw the circuit between terminals **P** and **Q** on Fig. 6.1 in the space to the right of **PQ**. [2]
- (ii) The entire receiving aerial is rotated slowly through  $180^\circ$  in the direction shown by the arrow. Explain clearly what will be observed on the ammeter and how the detected signal varies.

.....

.....

.....

.....

.....

.....

.....

.....

..... [3]

[Total: 17]

Turn over

7 (a) State **one** experiment for each case which provides evidence that electromagnetic radiation can behave like

(i) a stream of particles, called *photons*

..... [1]

(ii) waves.

..... [1]

(b) A beam of ultraviolet light is incident on a clean metal surface. The graph of Fig. 7.1 shows how the maximum kinetic energy  $KE_{\max}$  of the electrons ejected from the surface varies with the frequency  $f$  of the incident light.

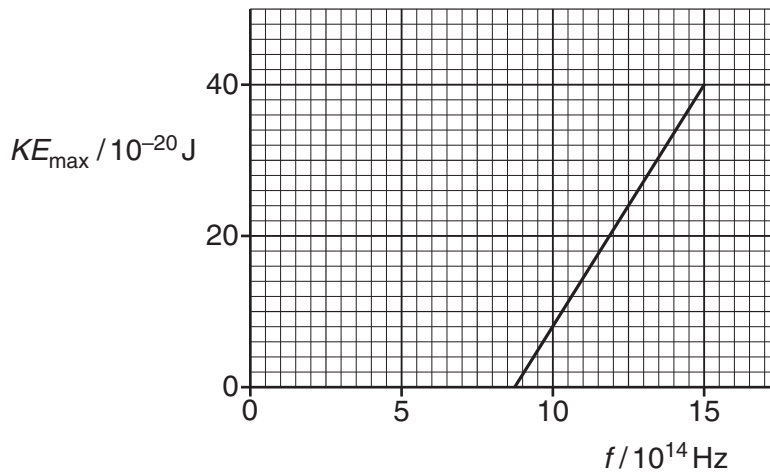

Fig. 7.1

(i) Define the work function  $\phi$  of the metal.

.....  
.....  
.....  
..... [1]



(ii) Write down the relationship between  $KE_{max}$  and  $f$ . Use it to explain why the y-intercept of the graph in Fig. 7.1 is equal to the work function of the metal and the gradient of the line is equal to the Planck constant.

.....  
.....  
.....  
.....  
.....  
.....  
..... [3]

(iii) Use data from Fig. 7.1 to find a value of

1 the Planck constant

Planck constant = ..... Js [2]

2 the threshold frequency of the metal

threshold frequency = ..... Hz [1]

3 the work function of the metal.

work function = ..... J [2]

[Total: 11]

END OF QUESTION PAPER

mock papers 4

1 The power of a 230V mains filament lamp is 40W.

(a) Define *power*.

.....  
..... [1]

(b) The lamp is connected to the 230V supply. Calculate

(i) the current *I* in the filament

$I = \dots\dots\dots$  A [2]

(ii) the resistance *R* of the filament.

$R = \dots\dots\dots$   $\Omega$  [1]

(c) The cross-sectional area of the wire of the filament is  $3.0 \times 10^{-8} \text{m}^2$ . The resistivity of the filament when the lamp is lit is  $7.0 \times 10^{-5} \Omega \text{m}$ . Use your answer to (b)(ii) to calculate the length *L* of the filament wire.

$L = \dots\dots\dots$  m [3]

(d) Explain whether the filament of a 60W, 230V lamp is thicker or thinner than that of the 40W, 230V lamp. The length and material of the filament are the same in both lamps.

.....  
.....  
.....  
.....  
.....  
.....  
.....  
..... [3]

(e) The 40W filament lamp is left on for 8 hours.

(i) Calculate the charge  $Q$  passing through the lamp in this time.

$Q = \dots\dots\dots C$  [2]

(ii) 1 Define the *kilowatt-hour*.

.....  
..... [1]

2 Calculate the cost of leaving the lamp switched on. The cost of 1 kWh is 22p.

cost =  $\dots\dots\dots p$  [2]

[Total: 15]

Turn over



(b) A circuit is set up to obtain the  $I-V$  characteristic shown in Fig. 2.1. It consists of a variable 0–6.0V d.c. power supply connected in **series** to a  $100\Omega$  resistor and the LED. Fig. 2.2 shows the variable supply. Draw the resistor, LED and suitable meters on the diagram between terminals **X** and **Y** to complete the circuit required for the experiment. [4]

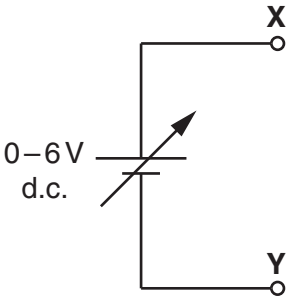

Fig. 2.2

(c) One or more LEDs are often used in places where, in the past, a filament lamp would have been used.  
Give **one** example of such a situation.  
Explain **one** advantage of using LEDs in place of a filament lamp in the situation you have chosen.

.....

.....

.....

.....

.....

.....

.....

..... [2]

[Total: 12]

Turn over



(b) Use Fig. 3.1 to calculate the voltmeter reading when the temperature of the oven is 240 °C.

voltmeter reading = ..... V [4]

(c) A light-dependent resistor (LDR) is another component used in sensing circuits.

(i) Complete Fig. 3.3 with an LDR between X and Y.

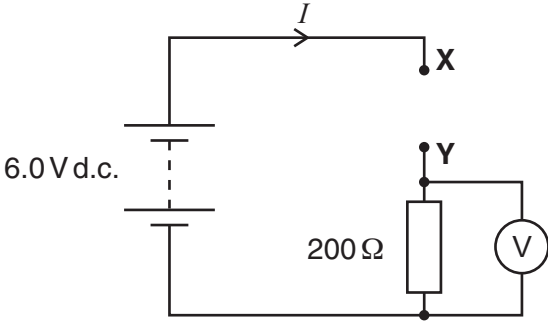

Fig. 3.3

[1]

(ii) State with a reason how the voltmeter reading varies as the intensity of the light incident on the LDR increases.

.....

.....

.....

.....

.....

.....

.....

..... [2]

[Total: 10]

Turn over

4 Fig. 4.1 shows part of a circuit where three resistors are connected together.

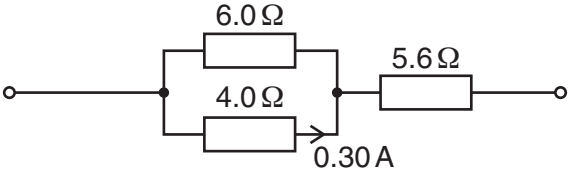

Fig. 4.1

The current in the  $4.0\ \Omega$  resistor is  $0.30\ \text{A}$ .

(a) Explain why the current in the  $6.0\ \Omega$  resistor is  $0.20\ \text{A}$ .

.....

.....

.....

.....

..... [2]

(b) (i) State the law which enables you to calculate the current in the  $5.6\ \Omega$  resistor.

.....

..... [1]

(ii) Calculate the current in the  $5.6\ \Omega$  resistor.

current = ..... A [1]

(c) Calculate the total resistance  $R$  of the combination of resistors.

$R =$  .....  $\Omega$  [3]



(d) To cause the current of 0.30 A in the 4.0  $\Omega$  resistor, the resistor combination is connected to a d.c. supply of electromotive force (e.m.f.) 5.0V.

(i) Explain the term *e.m.f.*

.....  
.....  
..... [2]

(ii) Show that the terminal potential difference across the supply is 4.0V.

[1]

(iii) Calculate the internal resistance of the supply.

internal resistance = .....  $\Omega$  [2]

[Total: 12]

Turn over

5 This question is about electrons and photons.

(a) Both electrons and photons can be considered as particles. State **two** differences between their properties.

.....  
.....  
..... [2]

(b) An electron is accelerated from rest through a p.d. of 5000V.

(i) Show that the energy gained by the electron is  $8.0 \times 10^{-16}$  J.

[2]

(ii) Show that the speed of the electron is about  $4 \times 10^7$  ms<sup>-1</sup>.

[3]

(c) (i) Explain what is meant by the de Broglie wavelength of an electron.

.....  
.....  
..... [1]

(ii) Calculate the de Broglie wavelength of the electron in (b).

wavelength = ..... m [3]

(d) Calculate the wavelength of a photon of energy  $8.0 \times 10^{-16} \text{ J}$ .

wavelength = ..... m [3]

(e) Photons of energy  $9.0 \times 10^{-19} \text{ J}$  are incident on a clean tungsten surface causing electrons to be emitted.

(i) State the name of this process.

..... [1]

(ii) Calculate the maximum kinetic energy of the emitted electrons. Tungsten has a work function of  $7.2 \times 10^{-19} \text{ J}$ .

maximum kinetic energy = ..... J [2]

(iii) Explain why your answer to (ii) is a maximum value.

.....  
.....  
.....  
.....  
..... [2]

[Total: 19]

Turn over

6 (a) Define the following terms as applied to wave motion

(i) *displacement and amplitude*

.....  
.....  
.....  
.....  
.....  
.....  
..... [2]

(ii) *frequency and phase difference.*

.....  
.....  
.....  
.....  
.....  
.....  
..... [2]

(b) Fig. 6.1 shows a transverse pulse on a *slinky*, an open wound spring, at time  $t = 0$ . The pulse is travelling at a speed of  $0.50 \text{ ms}^{-1}$  from left to right. The front of the pulse is at point X,  $0.25 \text{ m}$  from the point P.

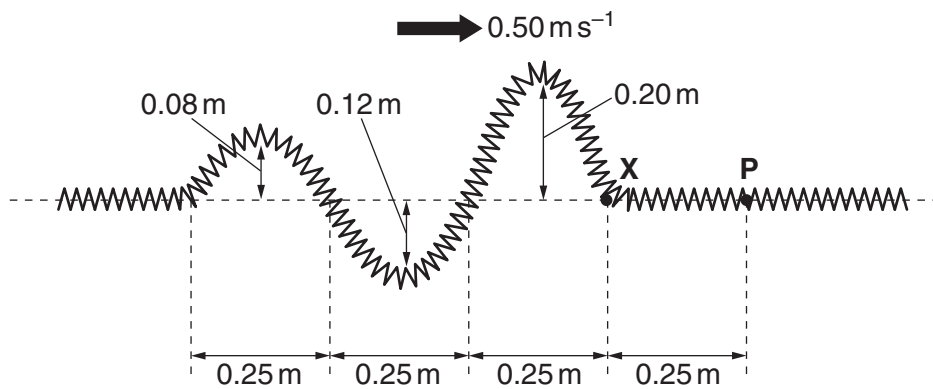
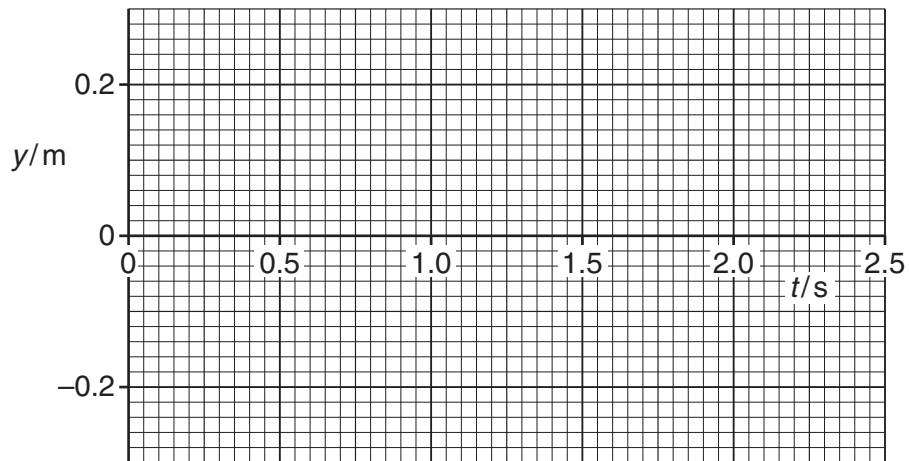

Fig. 6.1

On Fig. 6.2 draw a displacement  $y$  against time  $t$  graph of the motion of point **P** on the slinky from  $t = 0$  to  $t = 2.5$ s.



**Fig. 6.2**

[4]

[Total: 8]

Turn over



- (b) A parallel beam of light from a hydrogen lamp is incident on a diffraction grating. The first order red spectral line at  $6.56 \times 10^{-7} \text{ m}$  is seen at an angle of  $11.4^\circ$  as shown in Fig. 7.2.

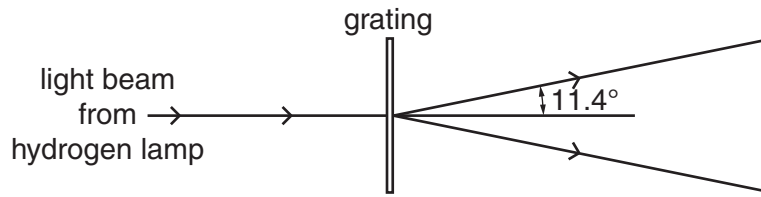

Fig. 7.2

- (i) Calculate

1 the separation  $d$  of the lines on the grating

$d = \dots\dots\dots \text{ m [3]}$

2 the number of lines per millimetre on the grating.

number =  $\dots\dots\dots \text{ lines mm}^{-1} [1]$

- (ii) The hydrogen lamp also emits blue light at a wavelength of  $4.86 \times 10^{-7} \text{ m}$ .

Draw rays on Fig. 7.2 to indicate roughly, that is without calculation, the direction of the **first** order blue spectral line as the rays leave the grating. [1]

[Total: 11]

Turn over

8 (a) State **two** properties shared by all electromagnetic waves which distinguish them from all other waves.

.....  
.....  
.....  
..... [2]

(b) The two columns below list four regions of the electromagnetic spectrum and four orders of magnitude of wavelength in m.

region	wavelength/m
microwaves	$10^{-12}$
ultra violet light	$10^{-8}$
gamma rays	$10^{-6}$
infra red light	$10^{-4}$

Draw a straight line from each **region** box to the corresponding **wavelength** box. [2]

(c) Fig. 8.1 shows a microwave receiver **R** placed between a microwave transmitter **T** and a flat metal sheet.

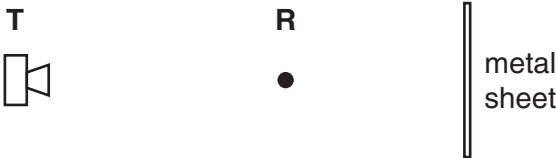

Fig. 8.1

(i) Explain why **R** receives two signals of different amplitude but of the same frequency.

.....  
.....  
.....  
.....  
..... [2]



- (ii) Explain why the strength of the detected signal varies between maximum and minimum values as **R** is moved towards or away from the metal sheet.



*In your answer you should make clear how the maxima and minima occur.*

.....

.....

.....

.....

.....

.....

.....

..... [3]

- (iii) Determine the wavelength of the microwaves given that the distance between adjacent positions of maximum and minimum signal strength is 7.5 mm.

wavelength = ..... mm [1]

- (iv) The amplitude of the signal from the transmitter is  $a$ . The amplitude of the two signals detected at **R** are  $0.8a$  and  $0.6a$ . The changes in amplitude of the detected signals are negligible as **R** moves 7.5 mm. Show that the ratio

$$\frac{\text{maximum intensity of detected signal}}{\text{minimum intensity of detected signal}}$$

is about 50.

[3]

[Total: 13]

END OF QUESTION PAPER

mock papers 5

1 A set of Christmas tree lights consists of 40 identical filament lamps connected in series across a supply of 240V.

(a) Define *resistance*.

.....  
..... [1]

(b) Each lamp when lit normally carries a current of 250 mA.

Calculate

(i) the potential difference *V* across a lamp

$V = \dots\dots\dots V$  [1]

(ii) the resistance *R* of a lamp.

$R = \dots\dots\dots \Omega$  [2]

(c) Fig. 1.1 shows the results of an experiment to find how the current in one of the lamps varies with the potential difference across it.

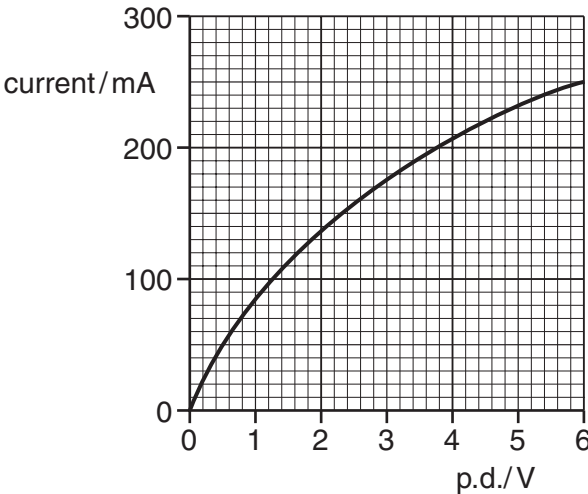

Fig. 1.1

(i) Draw a diagram of the circuit that you would use to perform this experiment.

[3]

(ii) The resistance of the lamp when at room temperature is  $10\Omega$ . Using Fig. 1.1 sketch a graph on the axes of Fig. 1.2 of the variation of resistance  $R$  with current for the lamp.

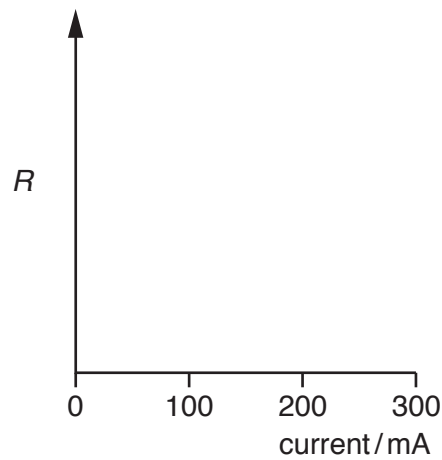

Fig. 1.2

[2]

(iii) Explain why the resistance of the lamp varies as shown by the graph you have drawn on Fig. 1.2.

.....

.....

.....

..... [2]

Turn over

(d) In an alternative design for the set of Christmas tree lights, a  $100\Omega$  resistor is connected in parallel with each lamp.

(i) Describe what happens to the brightness in each set of lamps when one lamp filament burns out.

1 *original set* .....  
..... [1]

2 *alternative set* .....  
.....  
..... [1]

(ii) Calculate the current drawn from the supply for the alternative set of lamps with all lamps working.

current = ..... A [3]

[Total: 16]

- 2 (a) A battery of e.m.f.  $E$  and internal resistance  $r$  delivers a current  $I$  to a circuit of resistance  $R$ .

Write down an equation for  $E$  in terms of  $r$ ,  $I$  and  $R$ .

..... [1]

- (b) A 'flat' car battery of internal resistance  $0.06\Omega$  is to be charged using a battery charger having an e.m.f. of  $14\text{V}$  and internal resistance of  $0.74\Omega$ , as shown in Fig. 2.1.

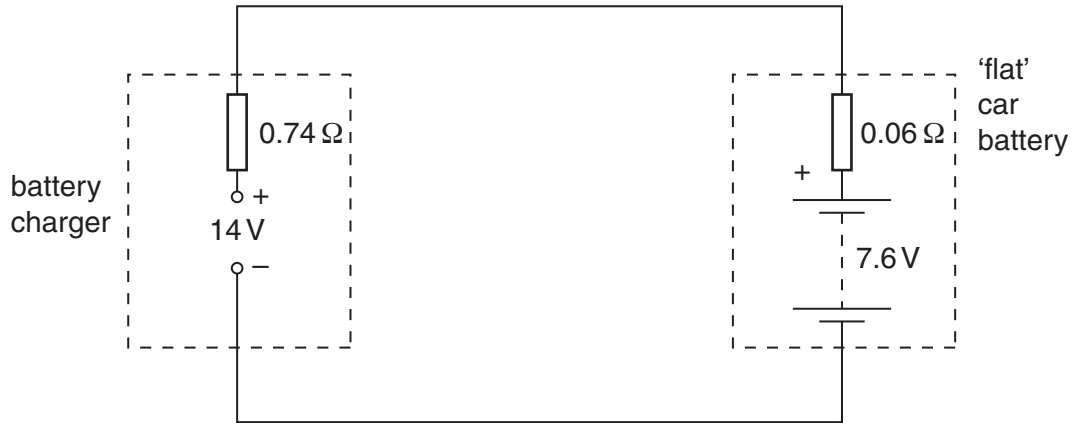

**Fig. 2.1**

You can see that the battery to be charged has its positive terminal connected to the positive terminal of the battery charger.

At the beginning of the charging process, the e.m.f. of the 'flat' car battery is  $7.6\text{V}$ .

- (i) For the circuit of Fig. 2.1, determine

- 1 the total resistance

resistance = .....  $\Omega$  [1]

- 2 the sum of the e.m.f.s in the circuit.

e.m.f. = .....  $\text{V}$  [1]

- (ii) State Kirchhoff's second law.

.....  
 ..... [1]

(iii) Apply the law to this circuit to calculate the initial charging current.

current = ..... A [2]

(c) For the majority of the charging time of the car battery in the circuit of Fig. 2.1, the e.m.f. of the car battery is 12V and the charging current is 2.5A. The battery is charged at this current for 6.0 hours. Calculate, for this charging time,

(i) the charge that passes through the battery

charge = ..... C [2]

(ii) the energy supplied by the battery charger of e.m.f. 14V

energy = ..... J [2]

(iii) the percentage of the energy supplied by the charger which is dissipated in the internal resistances of the battery charger and the car battery.

percentage of energy = ..... % [2]

[Total: 12]

Turn over

- 3 Fig. 3.1 shows a thermistor and fixed resistor of  $200\Omega$  connected through a switch **S** to a 24V d.c. supply of negligible internal resistance. The voltmeter across the fixed resistor has a very high resistance.

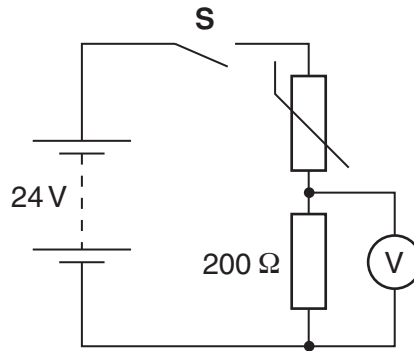

Fig. 3.1

- (a) When the switch **S** is closed the voltmeter initially measures 8.0V.

Calculate

- (i) the current  $I$  in the circuit

$$I = \dots\dots\dots \text{ A [2]}$$

- (ii) the potential difference  $V_T$  across the thermistor

$$V_T = \dots\dots\dots \text{ V [1]}$$

- (iii) the resistance  $R_T$  of the thermistor

$$R_T = \dots\dots\dots \Omega [2]$$

- (iv) the power  $P_T$  dissipated in the thermistor.

$$P_T = \dots\dots\dots \text{ W [2]}$$

- (b) A few minutes after closing the switch **S** the voltmeter reading has risen to a steady value of 12V. The value of the fixed resistor remains at 200Ω.

Explain why

- (i) the potential difference across the fixed resistor has increased

.....  
.....  
.....  
..... [3]

- (ii) the resistance of the thermistor must now be 200Ω.

.....  
..... [1]

- (c) Sketch, on the labelled axes of Fig. 3.2 below, a possible *I-V* characteristic for:

- (i) the fixed resistor. Label it **R**. [2]  
(ii) the thermistor. Label it **T**. [2]

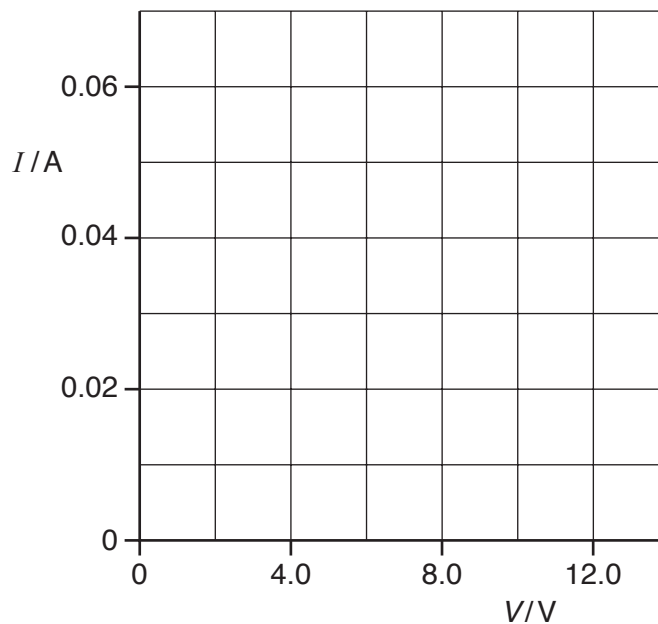

Fig. 3.2

[Total: 15]

Turn over



4 (a) (i) Both electromagnetic waves and sound waves can be **reflected**. State **two** other wave phenomena that apply to both electromagnetic waves and sound waves.

1. ....

2. .... [2]

(ii) Explain why electromagnetic waves can be polarised but sound waves cannot be polarised.

.....

..... [1]

(iii) Describe briefly an experiment to demonstrate the polarisation of microwaves in the laboratory.



*In your answer you should make clear how your observations demonstrate polarisation.*

.....

.....

.....

..... [4]

(b) A sound wave emitted by a loudspeaker consists of a single frequency. Fig. 4.1 shows the displacement against time graph of the air at a point **P** in front of the speaker.

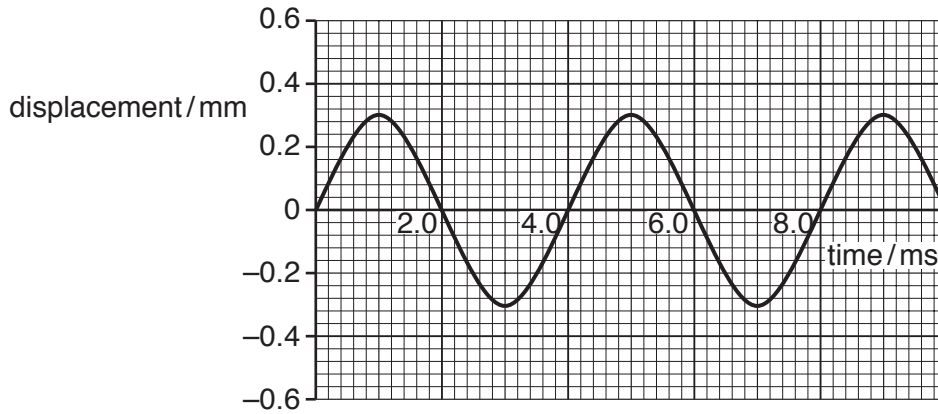

**Fig. 4.1**

(i) Use Fig. 4.1 to find

1 the amplitude of the air motion

amplitude = ..... mm [1]

2 the frequency of the sound wave.

frequency = ..... Hz [2]

Turn over



5 (a) When used to describe stationary (standing) waves explain the terms

(i) node ..... [1]

(ii) antinode. .... [1]

(b) Fig. 5.1 shows a string fixed at one end under tension. The frequency of the mechanical oscillator close to the fixed end is varied until a stationary wave is formed on the string.

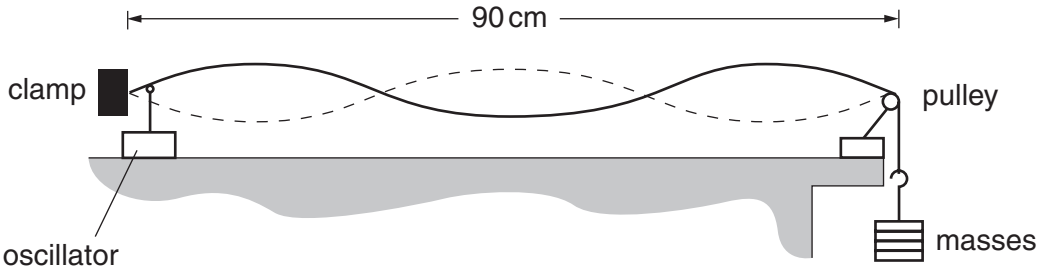

Fig. 5.1

(i) Explain with reference to a progressive wave on the string how the stationary wave is formed.

..... [3]

(ii) On Fig. 5.1 label one node with the letter N and one antinode with the letter A. [1]

(iii) State the number of antinodes on the string in Fig. 5.1.

number of antinodes = ..... [1]

(iv) The frequency of the oscillator causing the stationary wave shown in Fig. 5.1 is 120Hz. The length of the string between the fixed end and the pulley is 90cm. Calculate the speed of the progressive wave on the string.

speed = ..... ms<sup>-1</sup> [3]

(c) The speed *v* of a progressive wave on a stretched string is given by the formula

$$v = k \sqrt{W}$$

where *k* is a constant for that string. *W* is the tension in the string which is equal to the weight of the mass hanging from the end of the string.

In (b) the weight of the mass on the end of the string is 4.0N. The oscillator continues to vibrate the string at 120Hz. Explain whether or not you would expect to observe a stationary wave on the string when the weight of the suspended mass is changed to 9.0N.

.....  
.....  
.....  
.....  
.....  
.....  
..... [3]

[Total: 13]

Turn over

- 6 (a) A parallel beam of red light of wavelength  $6.3 \times 10^{-7}$  m from a laser is incident normally on a diffraction grating as shown in Fig. 6.1.

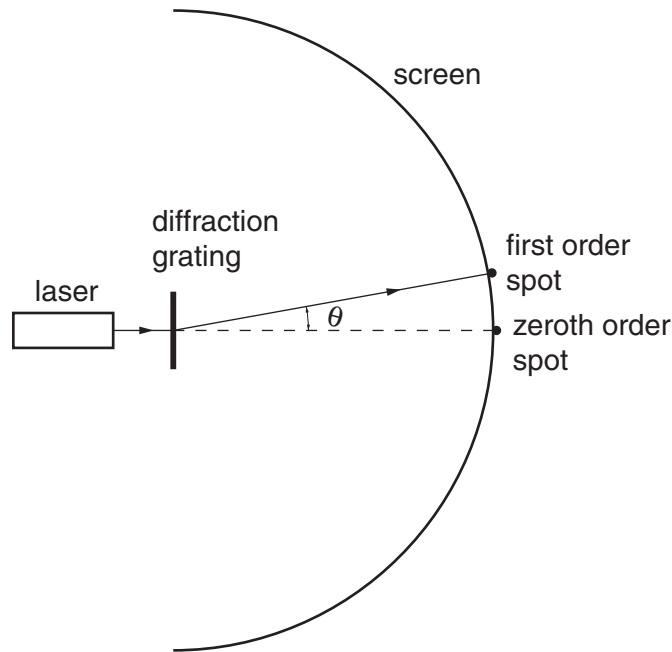

Fig. 6.1

Bright red spots are observed on the curved screen placed beyond the grating.

- (i) The diffraction grating has 300 lines per millimetre. Show that the separation  $d$  between adjacent lines of the grating is  $3.3 \times 10^{-6}$  m.

[1]

- (ii) Calculate the angle  $\theta$  at which the first order red spot is seen. This is the first spot away from the straight through position.

$\theta = \dots\dots\dots$  degrees [3]

- (iii) The screen curves around the full  $180^\circ$  in front of the grating. Explain why there are eleven bright red spots on the screen.

.....  
.....  
.....  
.....  
..... [3]

(b) Calculate

(i) the energy of each photon of light emitted by the laser at a wavelength of  $6.3 \times 10^{-7}$  m

energy = ..... J [2]

(ii) the number of photons emitted each second to produce a power of 0.50 mW.

number = ..... [2]

(c) (i) A beam of electrons in a vacuum can travel through a thin sheet of graphite perpendicular to the beam to produce a diffraction pattern of rings on a fluorescent screen beyond the graphite sheet. Explain why this pattern is produced.

.....  
.....  
.....  
.....  
..... [3]

(ii) Calculate

1 the speed  $v$  of electrons with a de Broglie wavelength of  $5.0 \times 10^{-11}$  m

$v =$  .....  $\text{ms}^{-1}$  [2]

2 the potential difference  $V$  required to accelerate the electrons to this speed.

$V =$  ..... V [3]

[Total: 19]

Turn over





