

NOTICE TO CUSTOMER:

The sale of this product is intended for use of the original purchaser only and for use only on a single computer system. Duplicating, selling, or otherwise distributing this product is a violation of the law ; **your license of the product will be terminated at any moment if you are selling or distributing the products.**

No parts of this book may be reproduced, stored in a retrieval system, or transmitted, in any form or by any means, electronic, mechanical, photocopying, recording, or otherwise, without the prior written permission of the publisher.

mock papers 1

SECTION A

1 A particle completes 6.0 revolutions in 4.0 s. The angular velocity, in rad s^{-1} , is

- A** 1.5
- B** 9.4
- C** 24
- D** 150

(Total for Question 1 = 1 mark)

2 Which of the following is equivalent to the unit for energy?

- A** $\text{kg m}^2 \text{s}^{-2}$
- B** kg m s^{-2}
- C** $\text{N s}^2 \text{kg}^{-1}$
- D** $\text{N}^2 \text{s}^2$

(Total for Question 2 = 1 mark)

3 A radium nucleus decays by emitting an alpha particle. The speed of the recoiling nucleus is small compared to the speed of the alpha particle. This is because the

- A** force acting on the recoiling nucleus is smaller than the force acting on the alpha particle
- B** momentum is mainly concentrated in the alpha particle
- C** momentum of the recoiling nucleus is smaller than the momentum of the alpha particle
- D** recoiling nucleus has a much larger mass than the alpha particle

(Total for Question 3 = 1 mark)

4 The potential difference across a capacitor is V . The energy stored on the capacitor is X joules. The potential difference across this capacitor is increased to $3V$. The energy stored, in joules, is increased to

- A $3X$
- B $6X$
- C $9X$
- D $27X$

(Total for Question 4 = 1 mark)

5 Figure 1 shows a vertical plane square coil of 50 turns, carrying a current of 3.0 A. The length of each side of the coil is 4.0 cm. Figure 2 shows a view of this coil from above within a horizontal magnetic field of flux density 0.20 T.

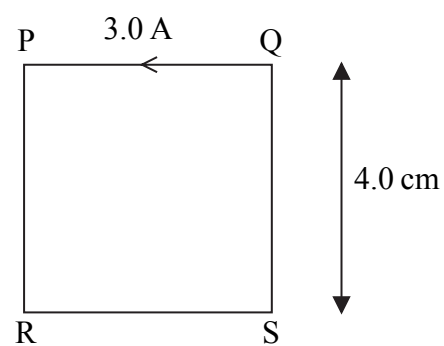

Figure 1

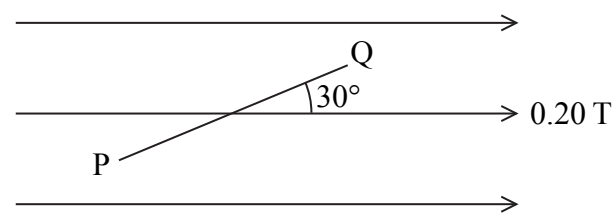

Figure 2

The force on side QS is

- A 120 N
- B 60 N
- C 1.2 N
- D 0.60 N

(Total for Question 5 = 1 mark)

Turn over ►

6 An electron gun uses a potential difference to accelerate electrons from rest to a speed of $2.00 \times 10^7 \text{ m s}^{-1}$.

(i) The potential difference is

- A** 569 V
- B** 1140 V
- C** 2280 V
- D** 4560 V

(ii) The de Broglie wavelength associated with electrons moving at $2.00 \times 10^7 \text{ m s}^{-1}$ is

- A** $3.3 \times 10^{-41} \text{ m}$
- B** $5.0 \times 10^{-14} \text{ m}$
- C** $3.6 \times 10^{-11} \text{ m}$
- D** $5.0 \times 10^{-8} \text{ m}$

(Total for Question 6 = 2 marks)

- 7 A particle detector shows tracks produced by two particles X and Y that were created by the decay of a lambda particle at O.

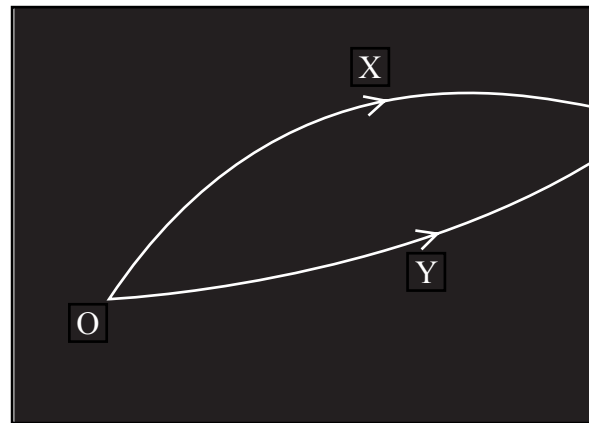

- (i) Which of the following is a valid conclusion from these facts?
- A X is a negatively charged particle.
 - B Y is a positively charged particle.
 - C The lambda particle is neutral.
 - D The magnetic field is acting into the plane of the paper.
- (ii) Which of the following is a correct statement about momentum at the decay?
- A The vector sum of the momenta of X and Y must equal that of the lambda particle.
 - B The momentum of X is equal to that of Y.
 - C The total momentum of this system is zero.
 - D The vector sum of the momenta of X and Y must equal zero.
- (iii) Which of the following is a correct statement about energy at the decay?
- A The energy of X must be greater than that of Y.
 - B The combined energy of X and Y must be more than the energy of the lambda particle.
 - C The mass of the lambda particle must equal the combined energy of X and Y.
 - D The mass energy of the lambda particle must equal the total energy of X and Y.

(Total for Question 7 = 3 marks)

TOTAL FOR SECTION A = 10 MARKS

Turn over ►

SECTION B

*8 Rutherford designed an experiment to see what happened when alpha particles were directed at a piece of gold foil. Summarise the observations and state the conclusions Rutherford reached about the structure of gold atoms.

(5)

.....

.....

.....

.....

.....

.....

.....

.....

.....

.....

.....

.....

.....

.....

(Total for Question 8 = 5 marks)

- 9 A 1.5 V cell is connected to a switch S, a neon lamp and a coil with many turns as shown. Nothing is observed when the switch is closed but the neon lamp flashes as soon as it is opened.
The neon lamp flashes when the potential difference across it is about 200 V.

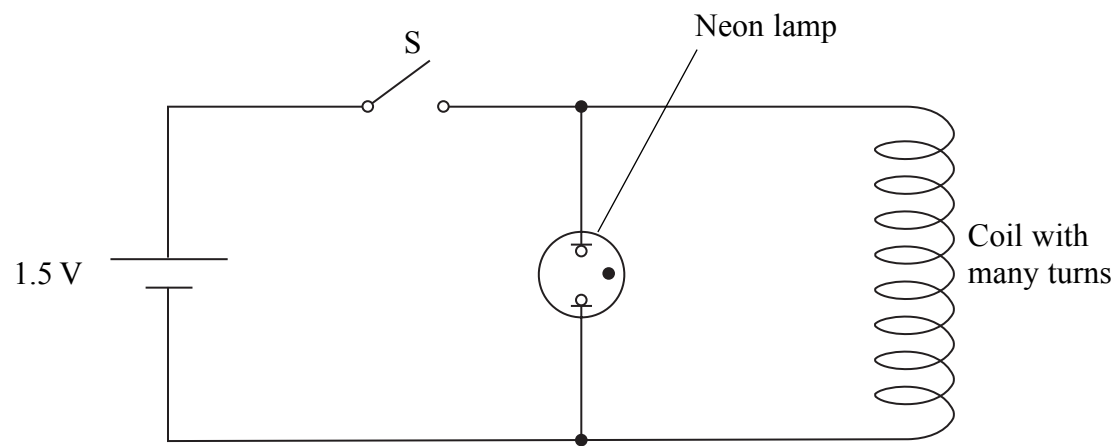

Use Faraday's law to explain why the lamp flashes once when the switch S is **opened**.

(4)

.....

.....

.....

.....

.....

.....

.....

.....

.....

.....

(Total for Question 9 = 4 marks)

Turn over ►

10 Liquid crystal displays (LCDs) are made from two parallel glass plates, $10\ \mu\text{m}$ apart, with liquid crystal molecules between them. The glass is coated with a conducting material.

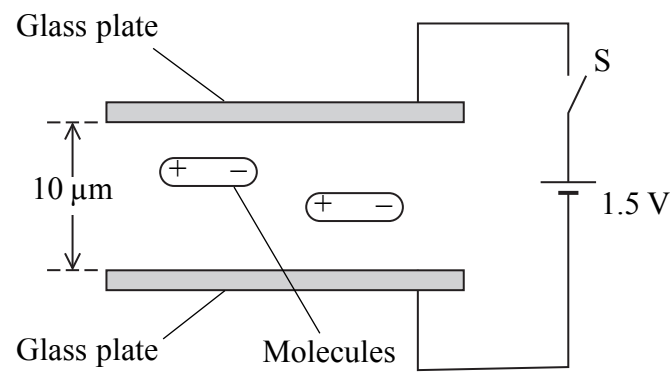

The molecules are positive at one end and negative at the other. They are normally aligned parallel with the glass plates as shown.

The switch S is closed and 1.5 V is applied across the glass plates.

(a) Calculate the electric field strength between the plates.

(2)

.....
.....
.....

Electric field strength =

(b) Explain what happens to the liquid crystal molecules.

(3)

.....
.....
.....
.....
.....
.....
.....

(Total for Question 10 = 5 marks)

11 The diagram represents a proton.



(a) Draw lines to represent its electric field.

(3)

(b) Calculate the electrostatic force on the electron in a hydrogen atom.

Average distance between proton and electron = 5.4×10^{-11} m

(3)

.....
.....
.....
.....
.....
.....
.....

Force =

(Total for Question 11 = 6 marks)

Turn over ►

12 Kingda Ka was the highest roller coaster in the world in 2007. A train is initially propelled along a horizontal track by a hydraulic system. It reaches a speed of 57 m s^{-1} from rest in 3.5 s. It then climbs a vertical tower before falling back towards the ground.

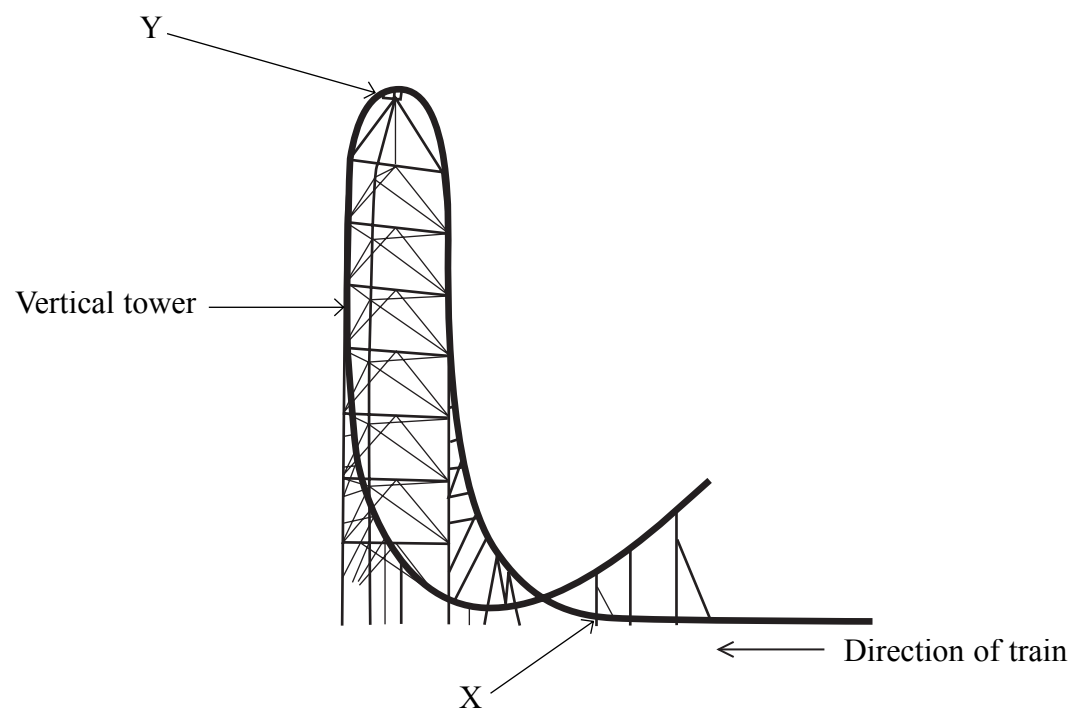

(a) Calculate the average force used to accelerate a fully loaded train along the horizontal track.

Total mass of fully loaded train = 12 000 kg

(2)

.....

.....

.....

.....

Force =

(b) Point X is just before the train leaves the horizontal track and moves into the first bend. Complete the free-body diagram below to show the two forces acting on a rider in the train at this point.

(3)

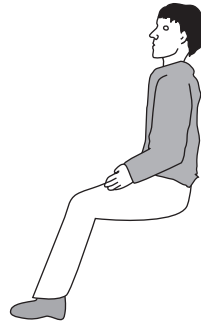

(c) The mass of the rider is m and g is the acceleration of free fall. Just after point X, the reaction force of the train on the rider is $4mg$ and can be assumed to be vertical. This is referred to as a g -force of $4g$. Show that the radius of curvature of the track at this point is about 100 m.

(3)

.....

.....

.....

.....

.....

.....

(d) Show that the speed of the train as it reaches the top of the vertical tower is about 20 m s^{-1} . Assume that resistance forces are negligible. The height of the vertical tower is 139 m.

(2)

.....

.....

.....

.....

Turn over ►

(e) Riders will feel momentarily weightless if the vertical reaction force becomes zero.
The track is designed so that this happens at point Y.

Calculate the radius of the track at point Y.

(2)

.....
.....
.....
.....

Radius =

(Total for Question 12 = 12 marks)

13 An uncharged capacitor is connected into a circuit as shown.

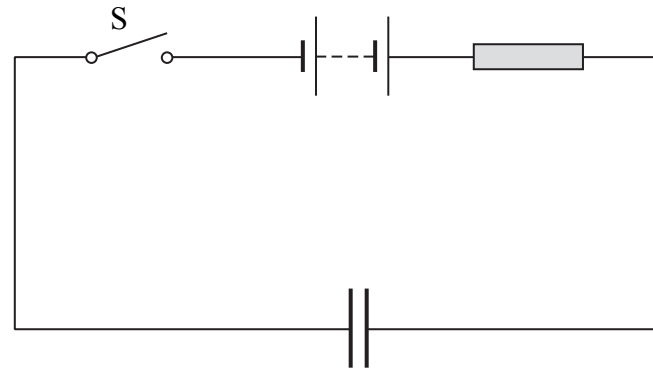

(a) Describe what happens to the capacitor when the switch S is closed.

(2)

.....

.....

.....

(b) A student models the behaviour of the circuit using a spreadsheet. The student uses a $100 \mu\text{F}$ capacitor, a $3.00 \text{ k}\Omega$ resistor and 5.00 V power supply. The switch is closed at time $t = 0 \text{ s}$.

	A	B	C	D	E
1	t / s	I / mA	$\Delta Q / \mu\text{C}$	$Q / \mu\text{C}$	p.d. across capacitor/V
2	0	1.67	167	167	1.67
3	0.1	1.11	111	278	2.78
4	0.2	0.74	74	352	3.52
5	0.3	0.49	49	401	4.01
6	0.4	0.33	33	434	4.34
7	0.5	0.22	22	456	4.56
8	0.6	0.15	15	471	4.71
9	0.7	0.10	10	480	4.80
10	0.8	0.07	7	487	4.87

(i) Explain how the value in cell C4 is calculated.

(2)

.....

.....

.....

(ii) Explain how the value in cell E3 is calculated.

(2)

.....

.....

.....

(c) The graph shows how the spreadsheet current varies with time.

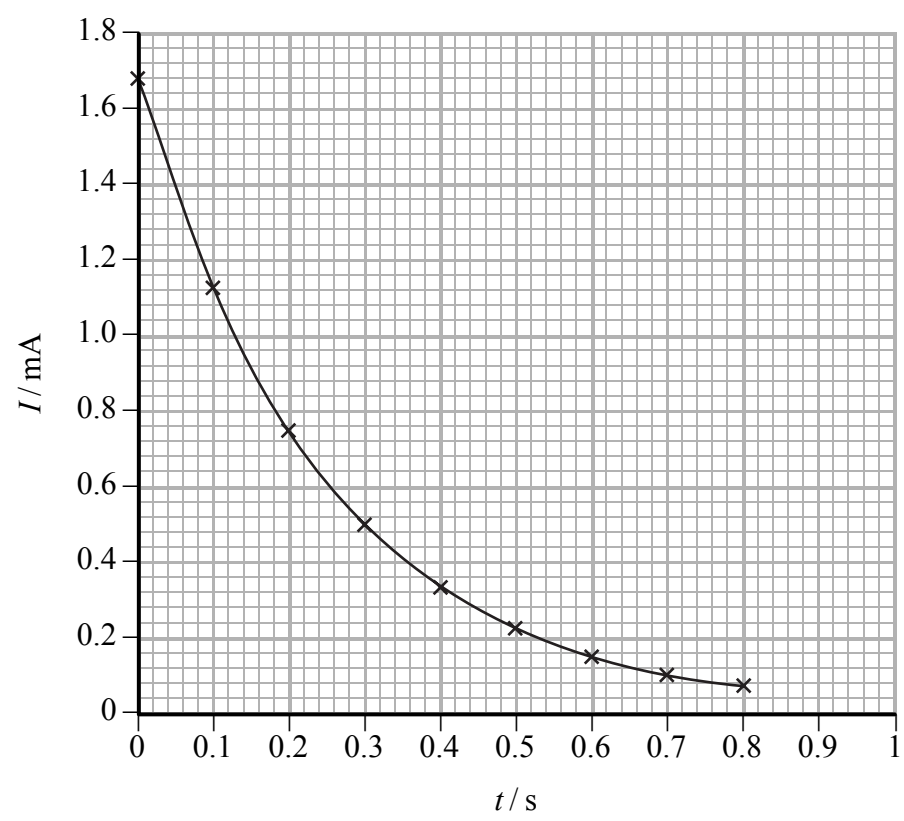

Turn over ►

(i) Use the graph to show that the time constant is approximately consistent with the component values.

(4)

.....

.....

.....

.....

.....

.....

.....

.....

.....

.....

.....

.....

(ii) The student thinks that the graph is an exponential curve. How would you use another graph to confirm this?

(3)

.....

.....

.....

.....

.....

.....

.....

.....

(Total for Question 13 = 13 marks)

***14** Pion radiotherapy is a new form of cancer treatment that has been extensively investigated for tumours of the brain. Pions are short lived sub-atomic particles and belong to a group called mesons.

(a) The following table lists some quarks and their charge.

Quark	Charge / e
Up (u)	$+\frac{2}{3}$
Down (d)	$-\frac{1}{3}$
Strange (s)	$-\frac{1}{3}$
Charm (c)	$+\frac{2}{3}$

On the list below circle the combination which could correspond to a π^+ pion.

(1)

uud $\bar{d}\bar{d}$ $u\bar{d}$ $s\bar{c}$

(b) The mass of a pion is $0.14 \text{ GeV}/c^2$. Calculate the mass of a pion in kg.

(3)

.....

.....

.....

.....

.....

.....

Mass = kg

(c) Pions can be produced by accelerating protons using a cyclotron. Briefly explain the role of electric and magnetic fields within a cyclotron.

(5)

.....

.....

.....

.....

.....

.....

.....

.....

.....

.....

.....

.....

.....

.....

.....

.....

.....

.....

.....

.....

.....

.....

(d) When pions are used to treat brain tumours they are slowed by the tissue in the brain and cause little damage. When a pion is moving very slowly it may be absorbed by the nucleus of an atom. The atom nucleus then becomes unstable and breaks up into several fragments.

Explain why these fragments shoot out in all directions.

(3)

.....

.....

.....

.....

.....

.....

.....

.....

.....

.....

.....

.....

.....

.....

.....

.....

.....

.....

.....

.....

.....

.....

(Total for Question 14 = 12 marks)

Turn over ►

15 The photograph shows the track of a positively charged particle either side of a lead plate.

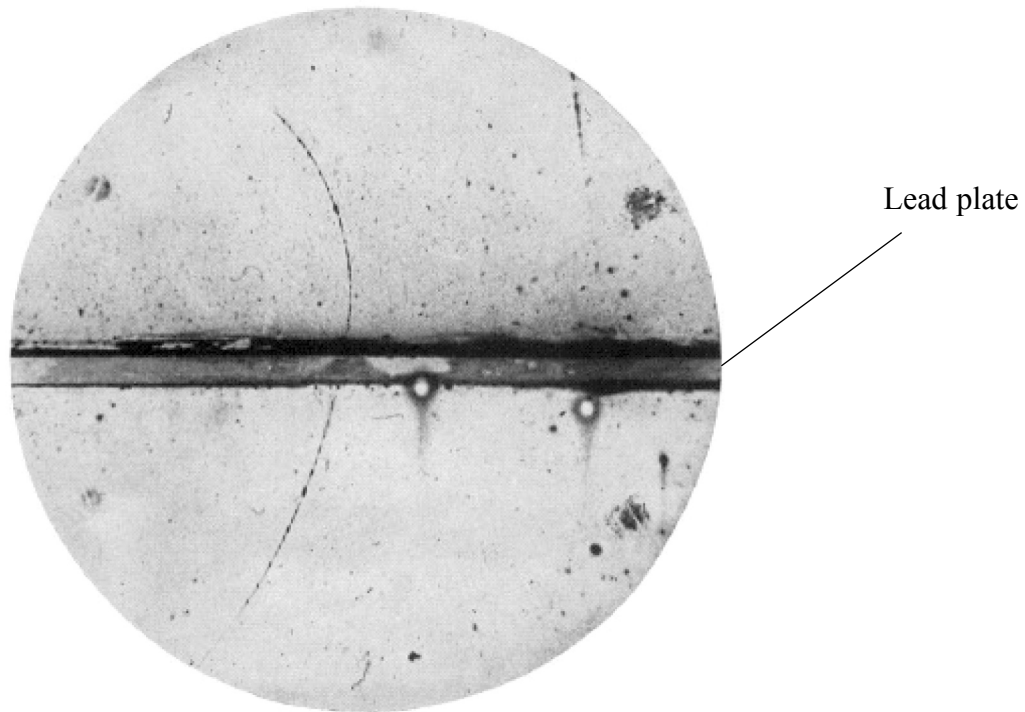

The particle was deflected by a magnetic field of magnetic flux density 1.5 T. The field is perpendicular to the plane of the photograph.

(a) (i) Estimate the actual radius of the track above the lead plate.

The lead plate is 6 mm thick.

(3)

.....

.....

.....

.....

.....

.....

Radius =

(ii) Calculate the momentum of this particle above the lead plate.
Particle charge = 1.6×10^{-19} C

(2)

.....
.....
.....
.....

Momentum =

(b) Explain whether this particle was moving up or down through the lead plate.

(3)

.....
.....
.....
.....
.....
.....

(c) On the list below circle the correct direction of the magnetic field.

(1)

Into the page from left to right down the page out of the page up the page

Turn over ►

(d) This particle was identified as a positron.

(i) Calculate the speed of the positron while it is moving above the lead plate. (2)

.....
.....
.....

Speed =

(ii) Comment on your answer. (2)

.....
.....
.....
.....

(Total for Question 15 = 13 marks)

TOTAL FOR SECTION B = 70 MARKS

TOTAL FOR PAPER = 80 MARKS

mock papers 2

SECTION A

1 The number of neutrons in a nucleus of $^{197}_{79}\text{Au}$ is

- A** 79
- B** 118
- C** 197
- D** 276

(Total for Question 1 = 1 mark)

2 Electric field strength can have the units

- A** C m^{-1}
- B** N C^{-1}
- C** N V^{-1}
- D** V m

(Total for Question 2 = 1 mark)

- 3 A tennis ball is travelling horizontally with a momentum of 0.4 kg m s^{-1} just before it is hit with a tennis racket. It rebounds horizontally from the tennis racket with a momentum of -0.6 kg m s^{-1} . The graph shows the variation in the momentum of the ball during this process.

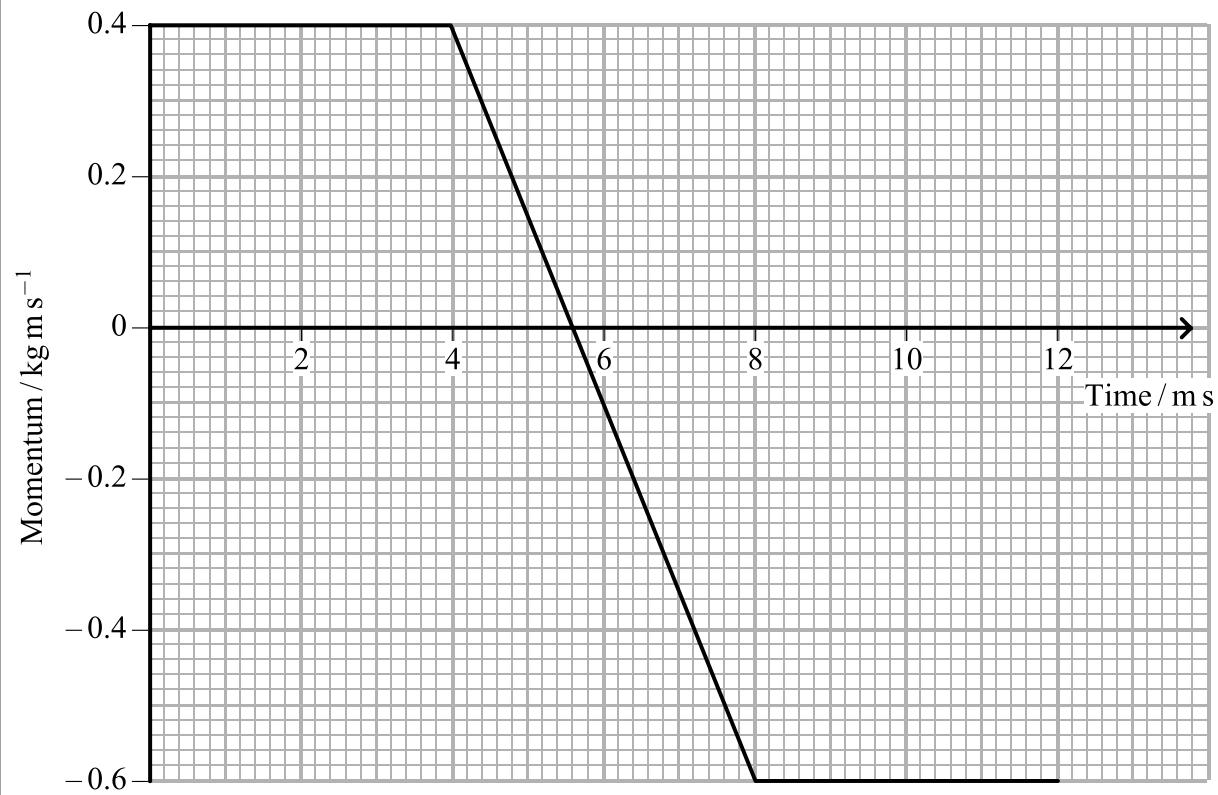

The force exerted by the tennis ball on the racket is

- A 12 N
- B 100 N
- C 250 N
- D 1000 N

(Total for Question 3 = 1 mark)

Turn over ►

4 The derivation of the formula $E_k = \frac{p^2}{2m}$ could include the expression

- A $\frac{1}{2} mv^2 = p^2$
- B $\frac{1}{2} m^2 v^2 = p^2$
- C $m^2 v^2 = \frac{p^2}{m}$
- D $m v^2 = \frac{p^2}{m}$

(Total for Question 4 = 1 mark)

5 The distance, in m, from an electron at which the electric field strength equals $6.4 \times 10^8 \text{ J C}^{-1} \text{ m}^{-1}$ is

- A 1.7×10^{-19}
- B 6.0×10^{-19}
- C 2.2×10^{-18}
- D 1.5×10^{-9}

(Total for Question 5 = 1 mark)

6 An uncharged capacitor is connected to a battery.

Which graph shows the variation of charge with potential difference across the capacitor?

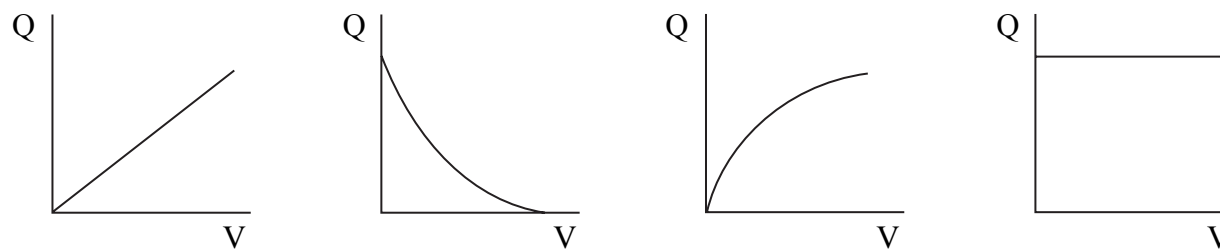

- A
- B
- C
- D

(Total for Question 6 = 1 mark)

7 Which of the following is **not** a valid conclusion from Rutherford's alpha particle scattering experiments?

- A The atom is mainly empty space.
- B The nucleus contains protons and neutrons.
- C The nucleus must be charged.
- D The nucleus must be very small compared to the atom.

(Total for Question 7 = 1 mark)

8 A 50 turn square coil, side 0.060 m, is placed in a magnetic field of flux density 0.40 T. The plane of the coil is at right angles to the direction of the magnetic field.

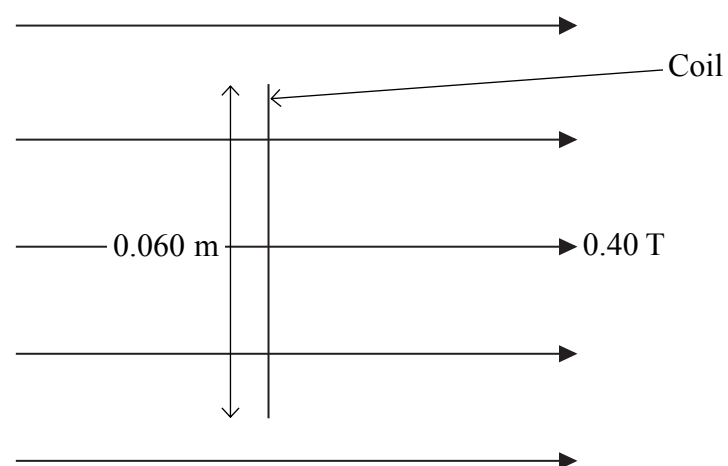

The flux linkage with the coil is

- A 0.072 Wb
- B 0.45 Wb
- C 1.2 Wb
- D 333 Wb

(Total for Question 8 = 1 mark)

Turn over ►

9 The diagram shows the path of an electron in a bubble chamber.

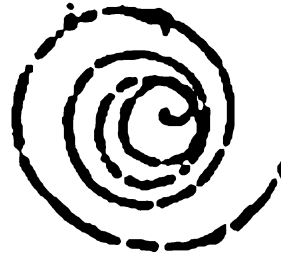

Which of the following can you deduce from the diagram?

- A The electron is moving anti-clockwise.
- B The electron is moving clockwise.
- C The magnetic field is acting out of the page.
- D The speed of the electron is increasing.

(Total for Question 9 = 1 mark)

10 Which one of the following quantities would the de Broglie equation be used to calculate?

- A The momentum of a moving particle.
- B The value of the Planck constant.
- C The wavelength of a moving electron.
- D The wavelength of a photon of light.

(Total for Question 10 = 1 mark)

TOTAL FOR SECTION A = 10 MARKS

SECTION B

Answer ALL questions in the spaces provided.

- 11** The diagram shows a horizontal wire which is at right angles to a magnetic field. The magnetic field is produced by a horseshoe magnet which is on a balance adjusted to read zero when the current in the wire is zero.

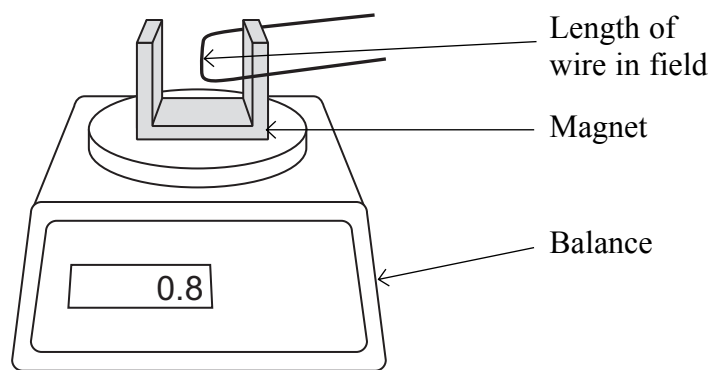

When the current is 4 A, the reading on the balance is 0.8 gram.

The length of wire in the magnetic field is 0.05 m.

Calculate the average magnetic flux density along the length of the wire.

(3)

.....

.....

.....

.....

.....

.....

.....

Magnetic flux density =

(Total for Question 11 = 3 marks)

Turn over ►

13 Astronauts can be weakened by the long-term effects of microgravity. To keep in shape it has been suggested that they can do some exercise using a Space Cycle: a horizontal beam from which an exercise bike and a cage are suspended. One astronaut sits on the exercise bike and pedals, which causes the whole Space Cycle to rotate around a pole. Another astronaut standing in the cage experiences artificial gravity. When rotated at 20 revolutions per minute, this is of similar strength to the gravitational field on Earth.

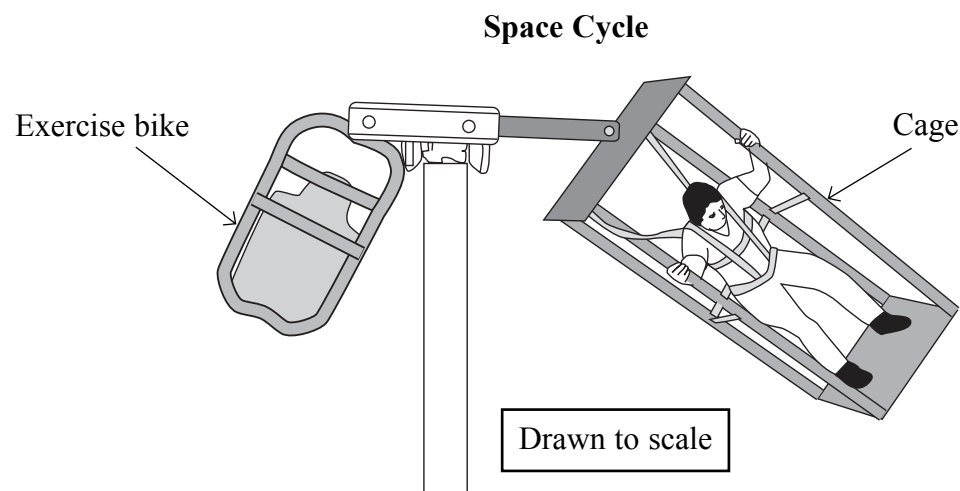

(a) Calculate the angular velocity, in rad s^{-1} , corresponding to 20 revolutions per minute. (2)

.....

.....

.....

.....

Angular velocity =

(b) Use the diagram to estimate the radius of the path followed by the cage's platform and hence calculate the platform's acceleration. (3)

.....

.....

.....

.....

.....

Acceleration =

(Total for Question 13 = 5 marks)

Turn over ▶

***14** How tiny bacteria move is of interest in nanotechnology. Mycobacteria move by ejecting slime from nozzles in their bodies.

Explain the physics principles behind this form of propulsion.

(4)

.....

.....

.....

.....

.....

.....

.....

.....

.....

.....

.....

.....

.....

.....

.....

.....

.....

.....

.....

.....

.....

.....

(Total for Question 14 = 4 marks)

- 15 Time-of-flight mass spectroscopy uses the arrangement below to measure the mass of molecules. A laser pulse knocks an electron out of a molecule in a sample leaving it as a positively charged ion.

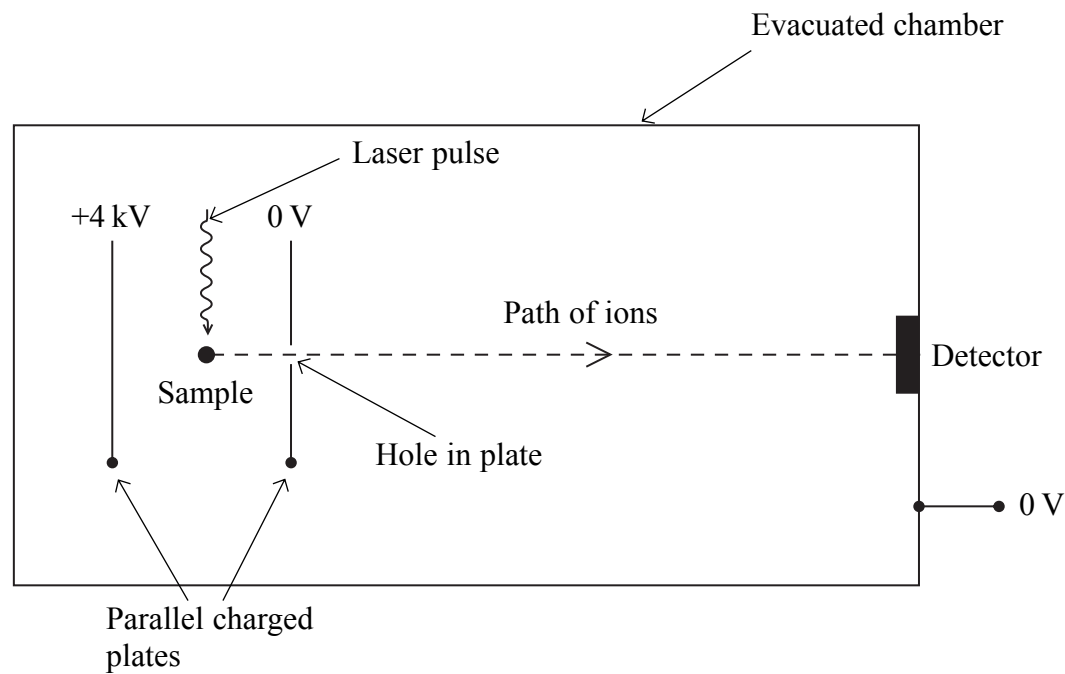

- (a) Add to the diagram to show the electric field lines between the two plates. (3)
- (b) The sample is midway between the charged plates. Show that the speed, v , of an ion as it reaches the hole in the plate is given by

$$v = \sqrt{\frac{6.4 \times 10^{-16} \text{ joule}}{m}}$$

where m is the mass of the molecule in kg.

(3)

.....

.....

.....

.....

.....

.....

.....

(c) The distance between the hole in the plate and the detector is 1.5 m. The time taken for a molecule to cover this distance is 23 μ s.

Calculate the mass of this molecule.

(3)

.....

.....

.....

.....

.....

.....

Mass =

(d) There is some uncertainty in the time a molecule with a particular mass will take to cover this distance.

Suggest **two** reasons for this.

(2)

1

.....

.....

2

.....

.....

(Total for Question 15 = 11 marks)

Turn over ►

16 Figure 1 shows the output from the terminals of a power supply labelled d.c. (direct current).

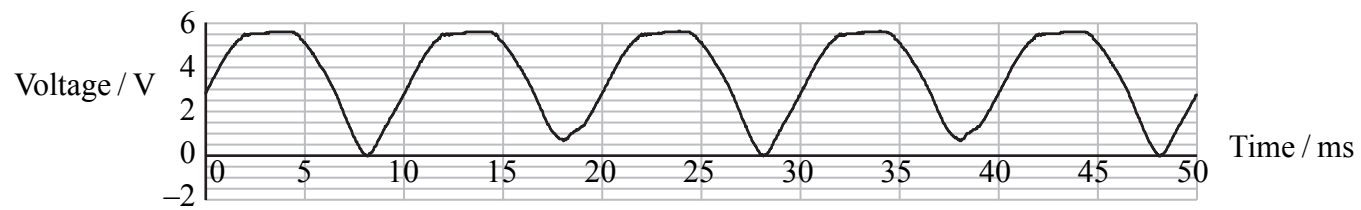

Figure 1

(a) An alternating current power supply provides a current that keeps switching direction.

Explain why the output shown in Figure 1 is consistent with the d.c. label.

(2)

.....

.....

.....

.....

(b) A teacher suggests that certain electronic circuits require a constant voltage supply to operate correctly.

(i) A student places a capacitor across the terminals of this power supply. Suggest how this produces a constant voltage.

(2)

.....

.....

.....

.....

(ii) She uses a $10\ \mu\text{F}$ capacitor. Calculate the maximum energy stored in the capacitor.

(3)

.....

.....

.....

.....

.....

.....

Maximum Energy =

(c) She now adds an electronic circuit to the power supply plus capacitor. Figure 2 shows the supply to the electronic circuit. This is shown in Figure 2.

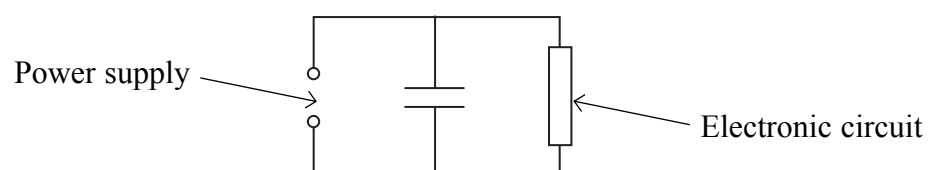

Figure 2

The variation in potential difference is shown by the graph in Figure 3.

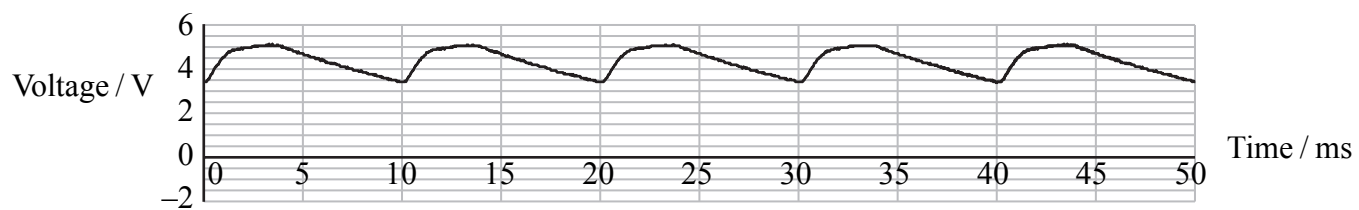

Figure 3

(i) Explain the shape of this graph.

(3)

.....

.....

.....

.....

.....

Turn over ►

(ii) Take readings from the graph to show that the resistance of the electronic circuit is in the range 1000Ω to 2000Ω .

(3)

.....

.....

.....

.....

.....

.....

(iii) Figure 3 shows that the voltage supplied to the electronic circuit still varies. How could the student make it more constant?

(1)

.....

.....

(Total for Question 16 = 14 marks)

17 A low-energy particle collides elastically with a stationary particle of the same mass. The particle enters from the left of the photograph.

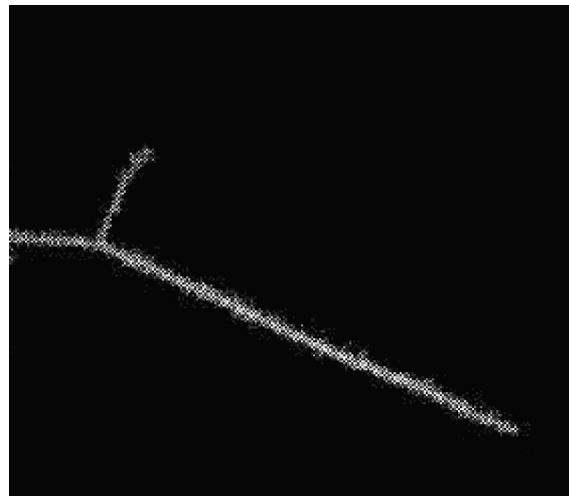

(a) State what is meant by collides *elastically*.

(1)

.....

.....

(b) Sketch a labelled vector diagram to show how the momentum of the initial moving particle relates to the momenta of the two particles after the collision.

(2)

(c) Use your answers to (a) and (b) to confirm that the angle between the subsequent paths of both particles must be 90° .

(2)

.....

.....

.....

(d) (i) Explain the process by which a proton is given energy in a particle accelerator. (3)

.....

.....

.....

.....

.....

.....

The diagram shows a collision between a high-energy proton (track from the left) and a stationary proton in a particle accelerator experiment.

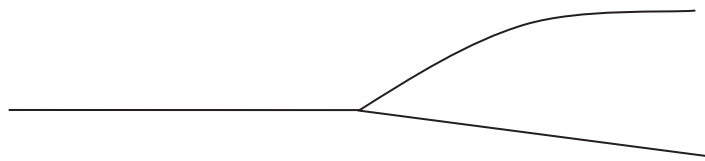

(ii) Explain why the angle between the two paths is not 90° . (2)

.....

.....

.....

.....

(e) Deduce the direction of the magnetic field in this particle accelerator experiment. Circle the correct direction from those given below. (1)

left to right across the paper out of the plane of the paper into the plane of the paper

(Total for Question 17 = 11 marks)

Turn over ►

***18** In 1961 Murray Gell-Mann predicted the existence of a new particle called an omega (Ω) minus. It was subsequently discovered in 1964.

At this time the quark model consisted of three particles, the properties of which are given in the table.

Quark	Charge	Predicted mass in MeV/c^2
Up (u)	$+\frac{2}{3}$	4
Down (d)	$-\frac{1}{3}$	4
Strange (s)	$-\frac{1}{3}$	80

(a) Explain what a charge of $+\frac{2}{3}$ means. (1)

.....

.....

(b) State the predicted mass of, and the charge on a \bar{s} . (2)

.....

.....

(c) Convert $4 \text{ MeV}/c^2$ to kg. (3)

.....

.....

.....

.....

.....

.....

.....

Mass = kg

(d) The event which led to the discovery of the omega minus particle can be summarised as follows. A negative kaon collided with a stationary proton and produced a positive kaon, a neutral kaon and the omega minus.

(i) Kaons K consist of combinations of either an up or down quark plus a strange quark. The omega minus consists of three strange quarks.

Complete the following table by ticking the appropriate boxes.

(2)

	Meson	Baryon	Nucleon	Lepton
Negative kaon				
Omega minus				

(ii) Write an equation using standard particle symbols to summarise this event.

(2)

.....

.....

.....

.....

(iii) The negative kaon consists of $\bar{u}s$. Deduce the quark structure of the other two kaons involved in this event.

(2)

.....

.....

.....

.....

Turn over ►

(iv) The total mass of the three particles created after this event is larger than the total mass of the two particles before. Discuss the quantities that must be conserved in interactions between particles and use an appropriate conservation law to explain this increase in mass.

(5)

.....

.....

.....

.....

.....

.....

.....

.....

.....

.....

.....

.....

.....

.....

.....

.....

.....

.....

.....

.....

.....

.....

(Total for Question 18 = 17 marks)

TOTAL FOR SECTION B = 70 MARKS

TOTAL FOR PAPER = 80 MARKS

mock papers 3

SECTION A

1 The area under a force-time graph represents

- A acceleration.
- B change in momentum.
- C displacement.
- D kinetic energy.

(Total for Question 1 = 1 mark)

2 A unit for flux linkage is the

- A tesla.
- B tesla per square metre.
- C weber.
- D weber per square metre.

(Total for Question 2 = 1 mark)

3 The electric field strength between two parallel plates is uniform. Which graph shows how the potential V varies with distance d from the positive plate?

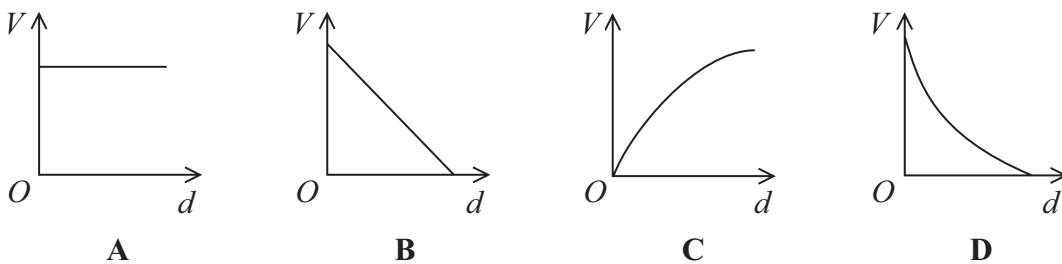

- A
- B
- C
- D

(Total for Question 3 = 1 mark)

4 The process by which electrons are released from a heated filament is known as

- A thermionic emission.
- B photoelectric emission.
- C ionisation.
- D excitation.

(Total for Question 4 = 1 mark)

5 A particle, mass 0.020 kg, is moving with an angular velocity of $3\pi \text{ rad s}^{-1}$ around a circle of radius 0.50 m. The force, in N, responsible for this motion is

- A 0.03π towards the centre of the circle.
- B 0.03π away from the centre of the circle.
- C $0.09\pi^2$ towards the centre of the circle.
- D $0.09\pi^2$ away from the centre of the circle.

(Total for Question 5 = 1 mark)

6 The force on a proton at a point in an electric field is $4.8 \times 10^{-19} \text{ N}$.

The electric field strength at that point is

- A $7.7 \times 10^{-38} \text{ N C}^{-1}$ in the opposite direction to the force.
- B $7.7 \times 10^{-38} \text{ N C}^{-1}$ in the same direction as the force.
- C $3.0 \times 10^{-19} \text{ N C}^{-1}$ in the opposite direction to the force.
- D 3.0 N C^{-1} in the same direction as the force.

(Total for Question 6 = 1 mark)

7 Which **one** of the following might **not** apply in interactions between sub atomic particles?

- A charge conservation
- B energy conservation
- C matter conservation
- D momentum conservation

(Total for Question 7 = 1 mark)

8 A pion could consist of

- A $u\bar{d}$
- B ud
- C uud
- D $uud\bar{d}$

(Total for Question 8 = 1 mark)

9 Data at the back of the examination paper can be used with the formula $\Delta E = c^2 \Delta m$ to calculate

- A the amount of energy in a proton.
- B the mass of coal that produces 6 MJ of energy when burnt.
- C the energy produced when an electron and a positron annihilate.
- D the energy produced when two protons collide.

(Total for Question 9 = 1 mark)

10 A particle X has kinetic energy E and momentum p . Another particle Y of the same mass as X has a momentum $2p$. The kinetic energy of Y is

- A $\frac{1}{2}E$
- B E
- C $2E$
- D $4E$

(Total for Question 10 = 1 mark)

TOTAL FOR SECTION A = 10 MARKS

SECTION B

11 A particle called a B meson has been observed to decay into an antiproton plus a lambda (Λ) particle. The lambda particle consisted of an up, a down and a charmed quark.

The following table summarises the charges on these quarks.

Quark	Charge / e
Up (u)	$+\frac{2}{3}$
Down (d)	$-\frac{1}{3}$
Charm (c)	$+\frac{2}{3}$

(a) Circle the correct word from the list below to describe the lambda particle. (1)

- Baryon Lepton Meson Anti-particle

(b) Calculate the charge on the lambda particle. (1)

.....

.....

Charge =

(c) Write an equation using standard particle symbols for this decay. (2)

.....

.....

.....

(Total for Question 11 = 4 marks)

*12 The photograph shows tracks produced by charged particles in a bubble chamber.

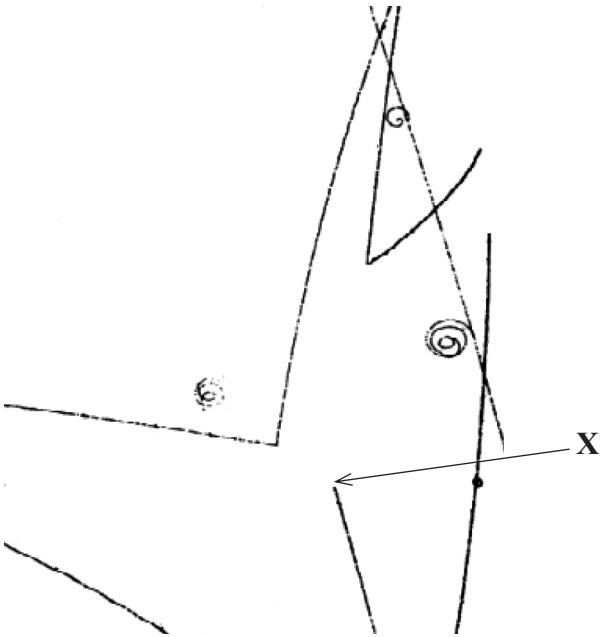

At X, an incoming charged particle interacts with a stationary proton to produce a neutral lambda particle and a neutral kaon particle. Both these particles later decay into other particles.

With reference to the photograph, describe and explain the evidence provided for this event.

(4)

.....

.....

.....

.....

.....

.....

.....

.....

.....

.....

(Total for Question 12 = 4 marks)

13 The simplified diagram shows a d.c. electric motor. The split ring commutator consists of two copper semicircular sections attached to either end of a coil. Fixed carbon brushes rub against, and make electrical connections to, the split ring commutator.

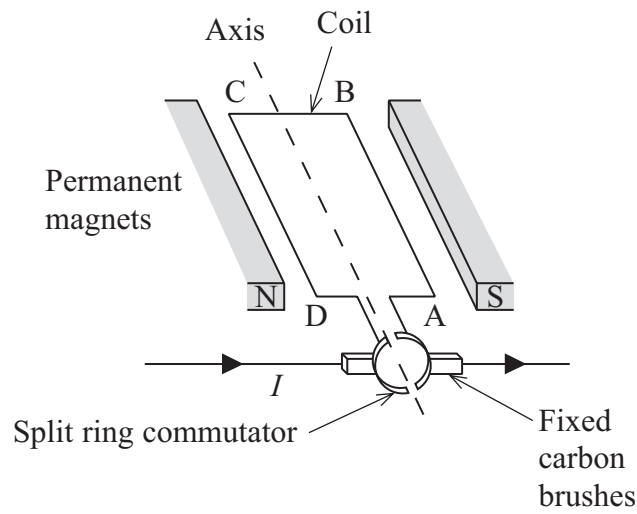

(a) Explain why the coil turns and why it continues to rotate. Add to the diagram to help your explanation.

(4)

.....

.....

.....

.....

.....

.....

.....

.....

.....

.....

.....

14 Muons have the same charge as electrons and can be produced by particle experiments. Muons belong to a family of fundamental particles called leptons. Muons have a short life and decay to electrons. Exotic atoms can be produced in which muons have been substituted for electrons. For example, muonic hydrogen consists of a proton and a muon.

(a) What is meant by a fundamental particle?

(1)

(b) Sketch the electric field around a muon.

(3)

(c) The mass of a muon is $106 \text{ MeV}/c^2$. Show that its mass is about 200 times that of an electron.

(3)

(d) Calculate the electric force between the muon and proton in the muonic hydrogen atom.

distance between muon and proton = 2.7×10^{-13} m

(2)

.....

.....

.....

.....

.....

.....

Electric force =

(e) Emission line spectra in the X-ray region of the electromagnetic spectrum can be detected from muonic hydrogen atoms.

Outline the atomic processes that produce emission spectra and suggest why they are X-rays in this case.

(3)

.....

.....

.....

.....

.....

.....

.....

.....

.....

.....

(Total for Question 14 = 12 marks)

15 A student sets up the circuit shown in the diagram.

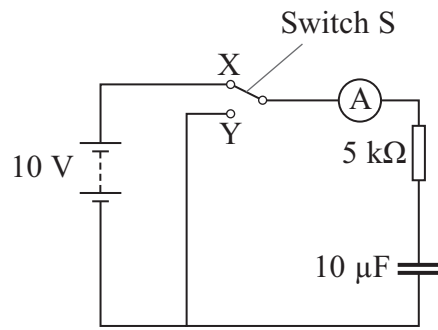

(a) (i) She moves switch S from X to Y. Explain what happens to the capacitor.

(2)

.....

.....

.....

(ii) On the axis below, sketch a graph to show how the current in the ammeter varies with time from the moment the switch touches Y. Indicate typical values of current and time on the axes of your graph.

(3)

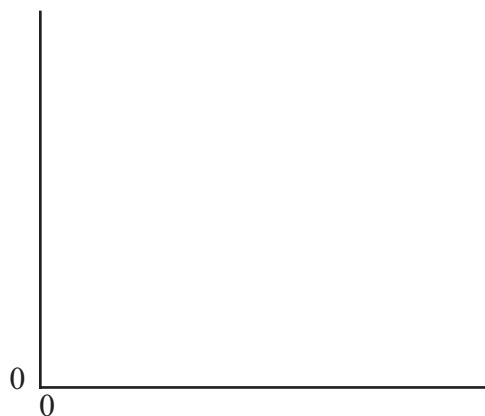

(iii) Describe how the graph would appear when the switch is moved back to X. (2)

.....

.....

.....

(b) Calculate the maximum energy stored on the capacitor in this circuit. (2)

.....

.....

.....

Maximum energy =

(c) The student wants to use this circuit to produce a short time delay, equal to the time it takes for the potential difference across the capacitor to fall to 0.07 of its maximum value.

Calculate this time delay. (2)

.....

.....

.....

Time delay =

(Total for Question 15 = 11 marks)

16 (a) Describe the key observations of the alpha particle scattering experiments which led to Rutherford's nuclear model of the atom.

(3)

.....

.....

.....

.....

.....

.....

.....

.....

(b) Experiments at Stanford University's linear accelerator (linac) accelerate electrons up to energies of 20 GeV.

(i) State the main features of a linac.

(3)

.....

.....

.....

.....

.....

(ii) Calculate the de Broglie wavelength of 20 GeV electrons. At these energies, the following relativistic equation applies $E = pc$.

(3)

.....

.....

.....

De Broglie wavelength =

(iii) Suggest why these electrons would be particularly useful for investigating nuclear structure.

(1)

.....

.....

.....

(iv) These electrons can be aimed at a hydrogen target. Some of these electrons are scattered at large angles by the protons whilst others pass straight through.

Suggest what this tells you about the structure of a proton.

(2)

.....

.....

.....

(v) The scattering process is inelastic. What is meant by an inelastic collision?

(1)

.....

.....

.....

(Total for Question 16 = 13 marks)

17 (a) A cyclotron can be used to accelerate charged particles.

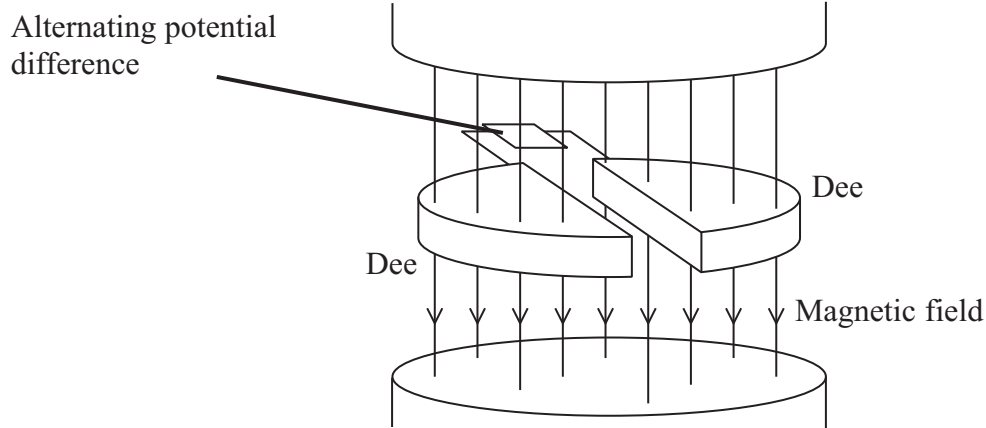

Explain the purpose of the magnetic field in a cyclotron. You may add to the diagram if you wish.

(2)

.....

.....

.....

(b) A beam of low-speed protons are introduced into a cyclotron.

(i) Show that the number of revolutions per second, f , completed by the protons is given by

$$f = \frac{eB}{2\pi m}$$

where e is the electronic charge
 B is the uniform magnetic flux density within the cyclotron
 m is the mass of the proton.

(3)

.....

.....

.....

.....

.....

.....

.....

(ii) An alternating potential difference is placed across the two dees to increase the energy of the protons.

Explain why the potential difference that is used is alternating.

(2)

.....

.....

.....

.....

(iii) Initially, whilst the proton speeds are low, the frequency at which the potential difference has to alternate is constant.

Explain how the frequency must change as the protons gain more and more energy.

(2)

.....

.....

.....

.....

(c) In the Large Hadron Collider at CERN, protons follow a circular path with speeds close to the speed of light. X-rays can be produced by free protons which are accelerating.

Explain why this provides a source of X-rays even though the speeds of the protons are constant.

(2)

.....

.....

.....

.....

(Total for Question 17 = 11 marks)

18 A student is using a ‘Newton’s Cradle’. This consists of a set of identical solid metal balls hanging by threads from a frame so that they are in contact with each other.

She initially pulls one ball to the side as shown.

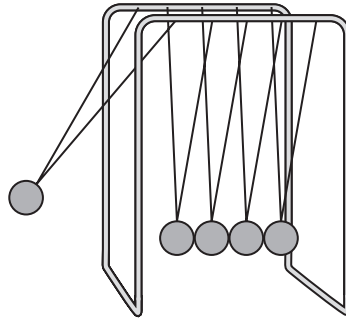

She releases the ball, it collides with the nearest stationary ball and stops. The ball furthest to the right immediately moves away. The middle three balls remain stationary.

*(a) Explain what measurements the student would take and describe how she would use them to investigate whether momentum had been conserved in this event.

(4)

.....

.....

.....

.....

.....

.....

.....

.....

.....

.....

.....

.....

.....

.....

.....

.....

.....

.....

.....

.....

.....

.....

(b) The student makes the following observations:

- the ball on the right returns and collides with a similar result; this repeats itself a number of times
- after a while, the middle balls are also moving
- shortly afterwards, the balls all come to rest.

Discuss these observations in terms of energy.

(3)

.....

.....

.....

.....

.....

.....

.....

.....

.....

(Total for Question 18 = 7 marks)

TOTAL FOR SECTION B = 70 MARKS

TOTAL FOR PAPER = 80 MARKS

mock papers 4

SECTION A

1 A body is falling freely under gravity. The rate at which the body's momentum is changing is equal to its

- A acceleration.
- B kinetic energy.
- C potential energy.
- D weight.

(Total for Question 1 = 1 mark)

2 A circular loop of thin wire is placed so that its plane is perpendicular to a magnetic field as shown.

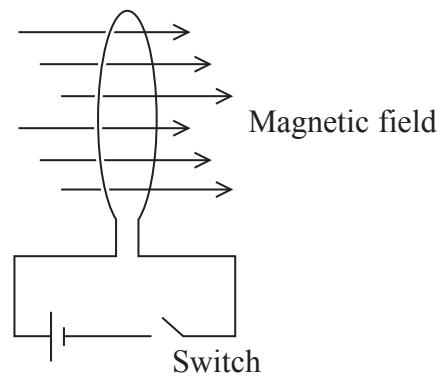

As the switch is closed, the loop of wire will

- A become a circle of smaller radius.
- B not change.
- C rotate about its centre.
- D rotate so that its plane is parallel to the field.

(Total for Question 2 = 1 mark)

3 The unit of the time constant for a resistor-capacitor circuit is

- A ΩF^{-1}
- B ΩC
- C s
- D s F

(Total for Question 3 = 1 mark)

4 The diagram represents two coils. Coil X has 1000 turns and a cross-sectional area of 10 cm^2 . It is carrying a current which produces a field of magnetic flux density 0.002 T . Coil Y has 50 turns and a cross-sectional area of 4 cm^2 .

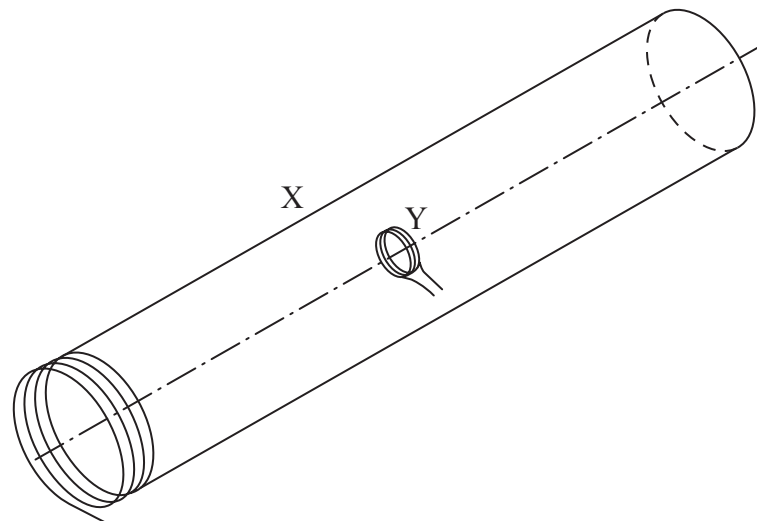

The flux linkage with coil Y is

- A 0.4 Wb
- B $2 \times 10^{-3} \text{ Wb}$
- C $4 \times 10^{-5} \text{ Wb}$
- D $8 \times 10^{-7} \text{ Wb}$

(Total for Question 4 = 1 mark)

Turn over ►

5 A car, mass m , drives over a circular hump-back bridge of radius r with a constant speed v .

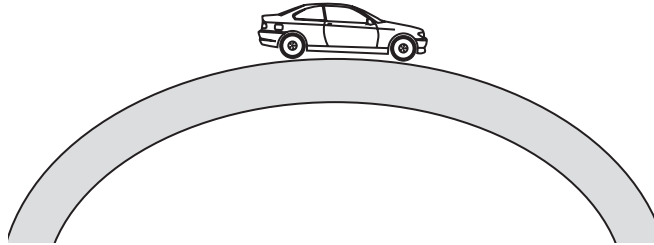

When it is at the top of the bridge, the force on the car from the bridge is given by

- A mg
- B $\frac{mv^2}{r} + mg$
- C $\frac{mv^2}{r} - mg$
- D $mg - \frac{mv^2}{r}$

(Total for Question 5 = 1 mark)

- 6 The diagram represents two identical coils X and Y. The planes of both coils are parallel and their centres lie on a common axis.

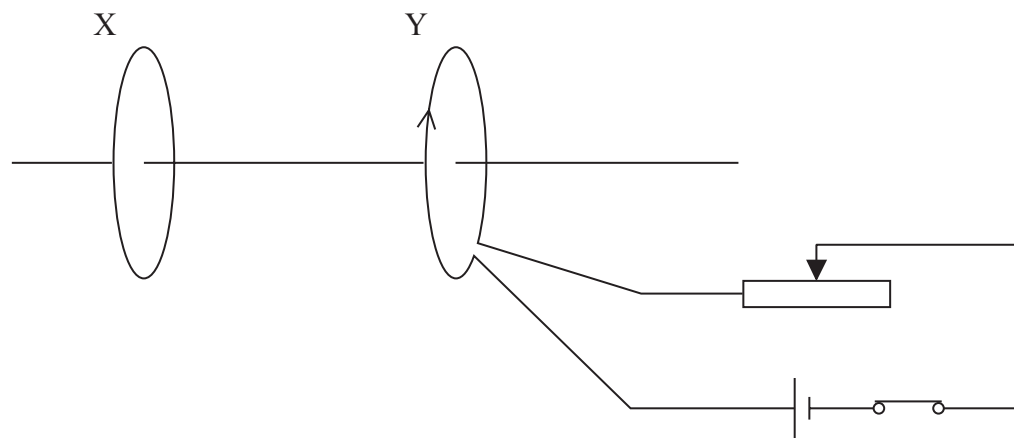

Coil Y is connected to a cell, a variable resistor and a closed switch.

Under which of the following circumstances would a current be induced in coil X in the same direction as the current shown in coil Y?

- A The coils are moved closer together.
- B The switch is opened.
- C The resistance of the variable resistor is decreased.
- D No change is made to the arrangement.

(Total for Question 6 = 1 mark)

- 7 A proton is moving in a circle, radius 1.5 m, within a magnetic field of flux density 0.020 T. The speed of the proton is

- A $4.8 \times 10^{-21} \text{ m s}^{-1}$
- B $2.9 \times 10^6 \text{ m s}^{-1}$
- C $5.3 \times 10^9 \text{ m s}^{-1}$
- D $1.8 \times 10^{25} \text{ m s}^{-1}$

(Total for Question 7 = 1 mark)

Turn over ►

8 A positron is found to have a mass of 1.8×10^{-29} kg. It can be concluded that this positron is

- A a proton.
- B travelling at close to the speed of light.
- C travelling at a non-relativistic speed.
- D travelling in a circle.

(Total for Question 8 = 1 mark)

9 The mass in MeV/c^2 of a 1.8×10^{-29} kg positron is

- A 10
- B 3.2×10^{-59}
- C 3.3×10^{-8}
- D 1.0×10^7

(Total for Question 9 = 1 mark)

10 The Large Hadron Collider is designed to accelerate protons to very high energies for particle physics experiments. Very high energies are required to

- A annihilate hadrons.
- B collide hadrons.
- C create particles with large mass.
- D produce individual quarks.

(Total for Question 10 = 1 mark)

TOTAL FOR SECTION A = 10 MARKS

SECTION B

11 The de Broglie wave equation can be written $\lambda = \sqrt{\frac{h^2}{2mE_k}}$ where m is the mass of a particle and E_k is its kinetic energy.

(a) Derive this equation. Use the list of equations at the end of this question paper.

(2)

.....

.....

.....

.....

.....

.....

.....

(b) An electron is accelerated through a potential difference of 2500 V.

Using the equation $\lambda = \sqrt{\frac{h^2}{2mE_k}}$ calculate the de Broglie wavelength of this electron.

(3)

.....

.....

.....

.....

.....

.....

.....

Wavelength =

(Total for Question 11 = 5 marks)

Turn over ►

12 A student carries out a practical involving a length of jelly. She places an infrared transmitter at one end and a receiver at the other. She obtains the following results.

Length of jelly l / cm	Receiver reading R / mV	$\ln(R / \text{mV})$
8.0	72	4.28
12.0	57	
16.0	43	3.76
20.0	33	
24.0	26	3.26

(a) Complete the table above and the graph below.

(2)

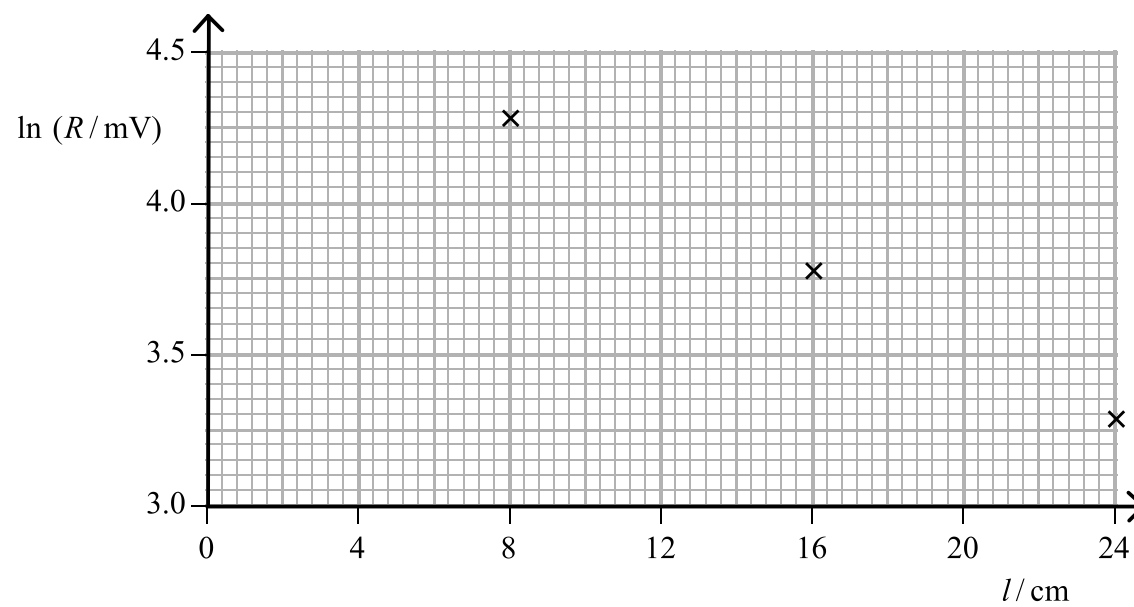

(b) The student reads that infrared light in jelly can be mathematically modelled using the equation $R = R_0 e^{-\mu l}$ where μ is a constant.

Use your graph to determine a value of μ for the jelly.

(2)

.....

.....

.....

$\mu =$

(Total for Question 12 = 4 marks)

13 A student needs to order a capacitor for a project. He sees this picture on a web site accompanied by this information: capacitance tolerance $\pm 20\%$.

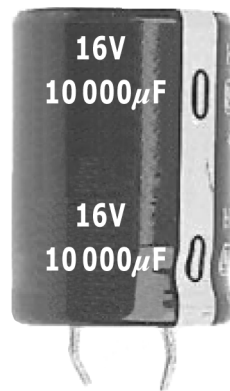

Taking the tolerance into account, calculate

(a) the maximum charge a capacitor of this type can hold.

(3)

.....

.....

.....

.....

.....

Maximum charge =

(b) the maximum energy it can store.

(2)

.....

.....

.....

.....

Maximum energy =

(Total for Question 13 = 5 marks)

Turn over ►

*14 A student has been asked to talk to her class about electric fields. As part of her presentation she hangs a table tennis ball, covered in a carbon coating, between two parallel plates connected to a high potential difference.

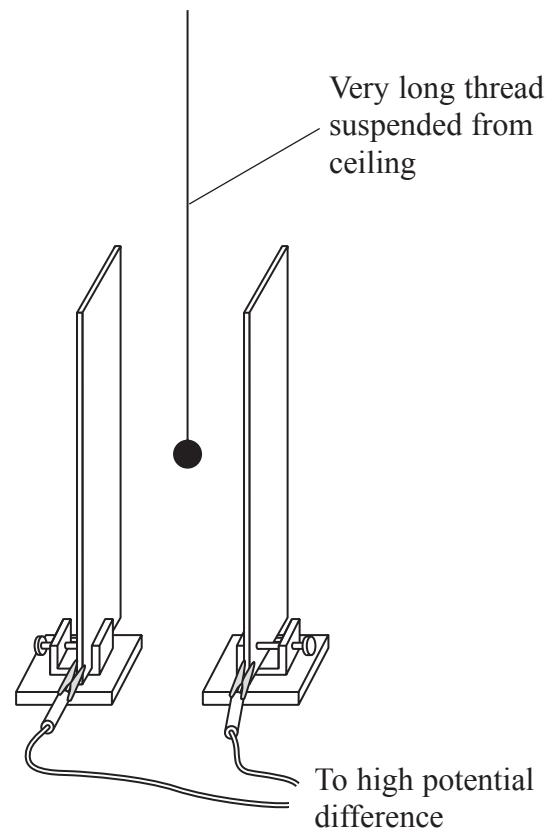

She pulls the ball across so that it touches one of the plates and then releases it. The ball then continues to bounce between the two plates. She sketches a graph of velocity v of the ball with time t from the time the ball leaves a plate until it returns.

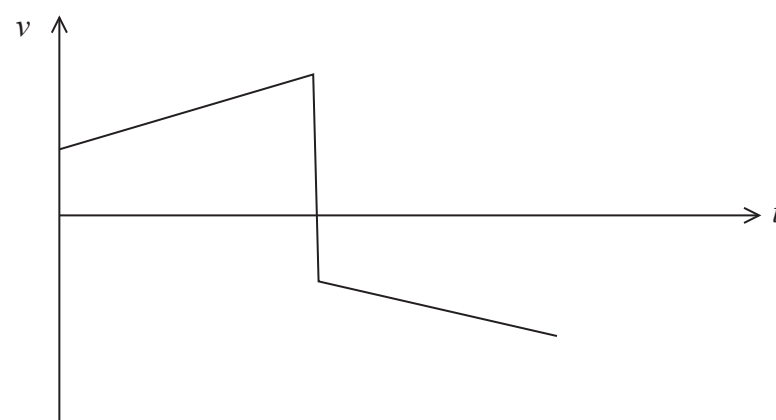

Explain the shape of the velocity-time graph for the ball from when it leaves one plate until it returns to the same plate. Ignore the weight of the ball.

(4)

.....

.....

.....

.....

.....

.....

.....

.....

.....

.....

.....

.....

.....

.....

.....

.....

.....

.....

.....

.....

.....

.....

(Total for Question 14 = 4 marks)

Turn over ▶

15 A student is carrying out an investigation into collisions between a bat and a ball.

The bat is pivoted at a point P so that it can swing freely. The centre of mass M of the bat swings through an arc and hits the ball. M moves through a height h as shown below.

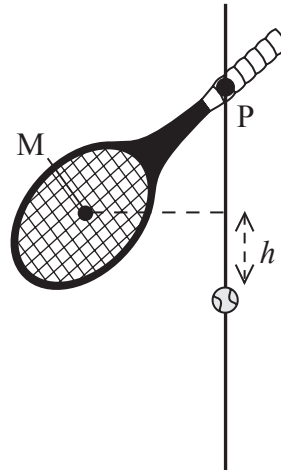

The ball is suspended vertically by a thread. The bat hits the ball which swings to a maximum height x .

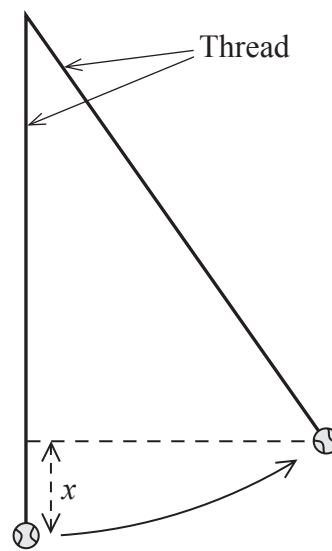

One set of measurements is $h = 0.030 \text{ m}$ $x = 0.10 \text{ m}$

(a) Show that the speed of M just before the collision is about 0.8 m s^{-1} .

(2)

.....

.....

.....

.....

(b) The student calculates the speed of the ball just after the collision to be 1.4 m s^{-1} .
The mass of the bat is 320 g and the ball is 55 g.

Calculate the speed of the bat just after the collision and state one assumption you make.
(4)

.....

.....

.....

.....

.....

.....

.....

.....

Speed of bat =

Assumption:

.....

(c) Determine whether the collision was elastic or inelastic.
(3)

.....

.....

.....

.....

.....

.....

.....

.....

(d) Discuss your conclusion with reference to possible uncertainties in the measurements of x .
(2)

.....

.....

.....

.....

(Total for Question 15 = 11 marks)

Turn over ►

16 (a) Sketch the electric field surrounding the gold nucleus drawn below.

(3)



(b) The spreadsheet shown approximately models the behaviour of an alpha particle as it approaches a gold nucleus.

The proton number of gold is 79.
mass of alpha particle = 6.64×10^{-27} kg

	A	B	C	D	E
1	Distance from gold nucleus / m	Magnitude of force on alpha particle / N	Time interval / s	Velocity at end of time interval / m s^{-1}	Displacement of alpha particle in time interval / m
2	8.60E-14	4.92E+00	1.00E-21	1.53E+07	1.56E-14
3	7.04E-14	7.34E+00	1.00E-21	1.42E+07	1.47E-14
4	5.57E-14	1.17E+01	1.00E-21	1.24E+07	1.33E-14
5	4.24E-14	2.02E+01	1.00E-21	9.34E+06	1.09E-14
6	3.15E-14	3.66E+01	1.00E-21	3.83E+06	6.58E-15
7	2.49E-14	5.84E+01	1.00E-21	-4.97E+06	-5.69E-16
8	2.55E-14	5.59E+01	1.00E-21	-1.34E+07	-9.18E-15
9	3.47E-14	3.02E+01	1.00E-21	-1.79E+07	-1.57E-14
10	5.03E-14	1.43E+01	1.00E-21	-2.01E+07	-1.90E-14

(i) Show how cell B3 is calculated.

(2)

.....

.....

.....

(ii) Show how cell D5 is calculated.

(3)

.....

.....

.....

(iii) Show how cell E6 is calculated.

(2)

.....

.....

(iv) Suggest a value for the maximum radius of a gold nucleus based on the results from this spreadsheet.

(1)

Maximum radius =

*(c) Describe the conclusions Rutherford reached about the structure of gold atoms as a result of the alpha particle scattering experiments.

(3)

.....

.....

.....

.....

.....

.....

.....

.....

.....

.....

(Total for Question 16 = 14 marks)

Turn over ►

17 A strong magnetic field of flux density B can be used to trap a positive ion by making it follow a circular orbit as shown.

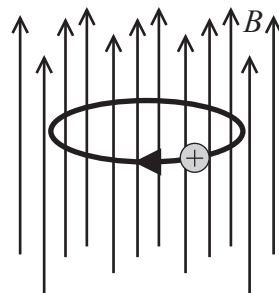

(a) Explain how the magnetic field maintains the ion in a circular orbit. You may add to the diagram above if you wish.

(2)

(b) Show that the mass m of the ion will be given by

$$m = \frac{Bq}{2\pi f}$$

where q is the charge on the ion and f is the number of revolutions per second.

(3)

(c) The above arrangement will not prevent a positive ion from moving vertically. To do this, a weak electric field is applied using the arrangement shown below.

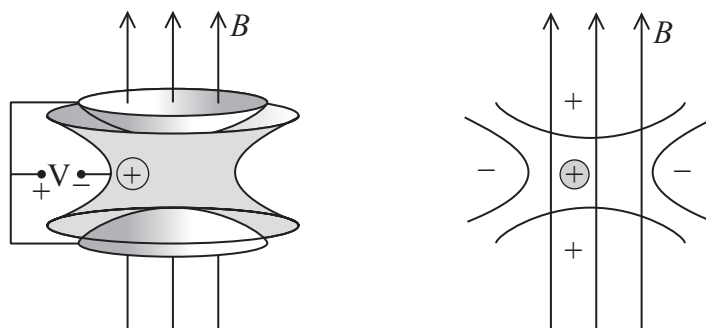

(i) Explain how the electric field prevents the ion moving vertically.

(2)

.....

.....

.....

(ii) This device is known as a Penning Trap. It can be used to determine the mass of an ion to an accuracy of 3 parts in 10 million.

Confirm that the mass of a sulphur ion can be measured to the nearest 0.00001u.

mass of sulphur ion = 32.0645u

(2)

.....

.....

(iii) Under certain conditions nuclei of sulphur emit a gamma ray with a known energy of 2.2 MeV.

Calculate the resulting loss in mass of a sulphur ion in u and confirm that this value could be determined by the Penning Trap technique.

(4)

.....

.....

.....

.....

.....

.....

.....

(Total for Question 17 = 13 marks)

Turn over ►

18 Evidence for a charm quark was discovered in 1974 at the linear accelerator (linac) at Stanford University.

(a) Why do the tubes of a linac become progressively longer down its length?

(1)

.....

.....

(b) This image shows the decay of a D^0 meson into a positively charged kaon and a negatively charged pion.

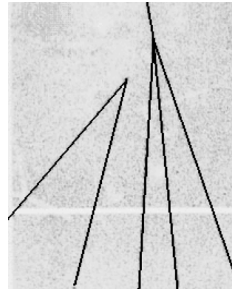

(i) Mark on the image the point P at which this decay occurs.

(1)

(ii) Give **two** reasons for choosing this point.

(2)

.....

.....

.....

(iii) Write an equation for this decay event.

(2)

.....

.....

.....

*(iv) State and discuss how three conservation laws apply to this decay event.

(6)

.....

.....

.....

.....

.....

.....

.....

.....

.....

.....

.....

.....

.....

.....

.....

.....

.....

.....

.....

.....

.....

.....

.....

Question 18 continues on the next page

Turn over ▶

(c) The table below shows some quarks and their properties.

Quark	Charge / e
Up (u)	$+\frac{2}{3}$
Down (d)	$-\frac{1}{3}$
Strange (s)	$-\frac{1}{3}$
Charm (c)	$+\frac{2}{3}$

(i) Circle the correct combination of quarks in the list below which corresponds to a D^0 meson.

(1)

$c\bar{u}$ cds $c\bar{s}$ cud

(ii) Suggest a possible quark combination of the positively charged kaon.

(1)

.....
.....

(Total for Question 18 = 14 marks)

TOTAL FOR SECTION B = 70 MARKS

TOTAL FOR PAPER = 80 MARKS

mock papers 5

SECTION A

1 The momentum of a particle is p . The kinetic energy of the particle is doubled.

The momentum is now

- A $\sqrt{2}p$
- B $2p$
- C $4p$
- D $8p$

(Total for Question 1 = 1 mark)

2 The diagram represents the collision between two sub-atomic particles P and Q moving with momenta 1 and 2 respectively. After the collision they have momenta 3 and 4 respectively.

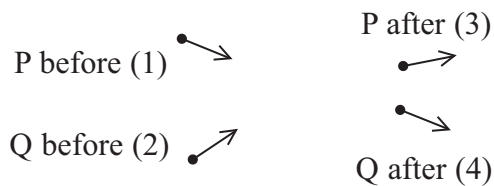

Which vector diagram best shows the correct relationship for the momenta of P and Q?

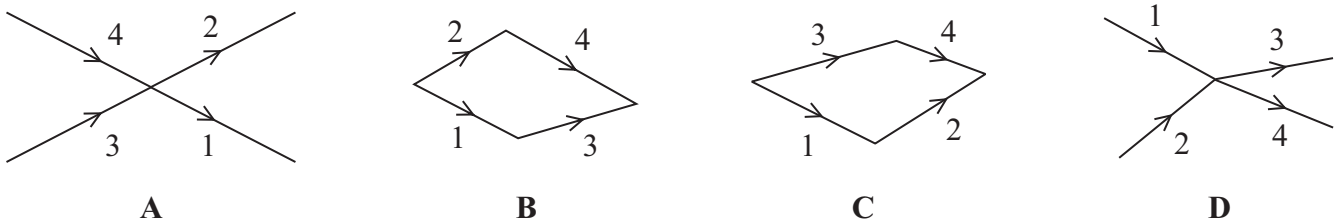

- A
- B
- C
- D

(Total for Question 2 = 1 mark)

3 A student is sitting on the right-hand side in a bus, facing the direction of travel. The bus goes round a bend to the left. The student remains in the same position within the bus.

The student experiences

- A a force to the left and a force to the right.
- B a resultant force to the left.
- C a resultant force to the right.
- D no resultant force.

(Total for Question 3 = 1 mark)

4 The unit of flux linkage is

- A T
- B $T m^{-2}$
- C Wb
- D $Wb m^{-2}$

(Total for Question 4 = 1 mark)

5 An electric motor is connected via a switch to a battery. A graph is plotted to show the variation of current I with time t . The switch is closed at time T .

Which of the following graphs is correct?

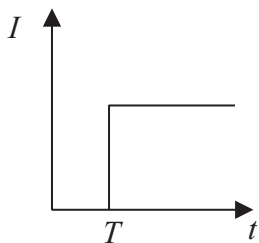

A

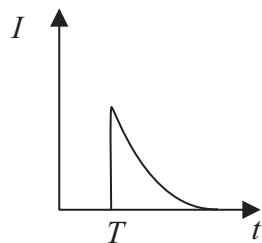

B

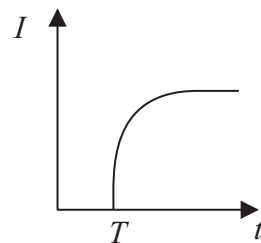

C

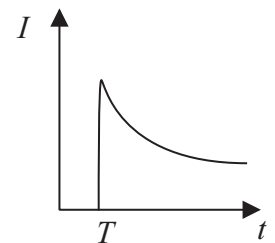

D

- A
- B
- C
- D

(Total for Question 5 = 1 mark)

6 Deuterium ${}^2_1\text{H}$ is an isotope of hydrogen.

An atom of deuterium has

		protons	neutrons	electrons
<input type="checkbox"/>	A	1	2	2
<input type="checkbox"/>	B	1	1	1
<input type="checkbox"/>	C	2	1	2
<input type="checkbox"/>	D	1	0	1

(Total for Question 6 = 1 mark)

7 The rest mass of a proton is 1.67×10^{-27} kg. This mass, in MeV/c^2 is approximately

- A 2.4×10^{-20}
- B 3.1×10^{-6}
- C 1.0
- D 940

(Total for Question 7 = 1 mark)

8 A positive kaon (K^+) is a meson which includes a strange quark. Its structure could be

- A $u\bar{s}$
- B us
- C $\bar{s}d\bar{d}$
- D usd

(Total for Question 8 = 1 mark)

9 The K^+ is likely to decay to

- A $\pi^+ + \mu^- + \bar{\nu}_\mu$
- B $\pi^+ + \pi^0$
- C $\pi^+ + \pi^-$
- D $\pi^0 + \mu^- + \bar{\nu}_\mu$

(Total for Question 9 = 1 mark)

10 The de Broglie wavelength of a moving tennis ball is calculated as 1×10^{-33} m. This means that the moving tennis ball

- A** diffracts through a narrow slit.
- B** does not behave as a particle.
- C** does not display wave properties.
- D** is travelling at the speed of light.

(Total for Question 10 = 1 mark)

TOTAL FOR SECTION A = 10 MARKS

SECTION B

11 (a) Explain what is meant by a uniform electric field.

(2)

.....

.....

.....

.....

.....

(b) Describe how a uniform electric field can be demonstrated in a laboratory.

(3)

.....

.....

.....

.....

.....

.....

.....

.....

.....

(Total for Question 11 = 5 marks)

***12** In 1820 Hans Oersted did an experiment with an electric current in a wire. He noticed that whenever the current was on, it affected a compass needle lying near the wire.

A few years later, André Ampere observed that two parallel wires attract each other if they are carrying current in the same direction.

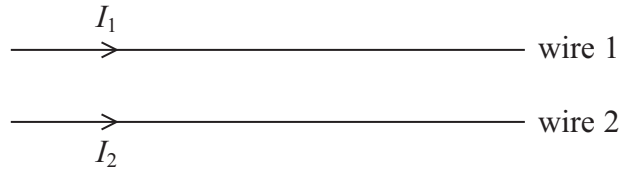

Explain André Ampere’s observation. You may wish to add to the diagram.

(5)

.....

.....

.....

.....

.....

.....

.....

.....

.....

.....

.....

(Total for Question 12 = 5 marks)

14 The photograph shows tracks in a particle detector.

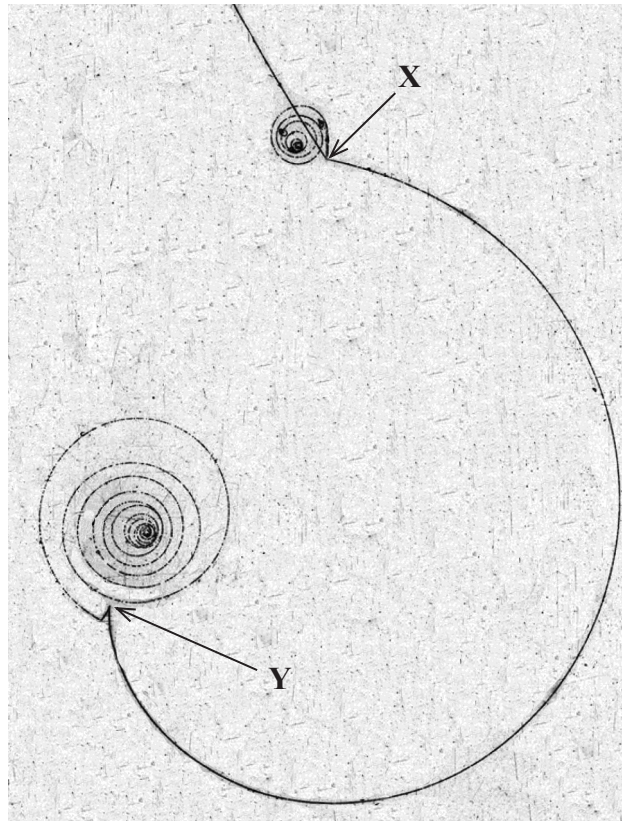

(a) Explain the role of a magnetic field in a particle detector.

(2)

.....

.....

.....

.....

(b) Explain how you can tell that track XY was produced by a particle moving from X to Y rather than from Y to X.

(2)

.....

.....

.....

.....

(c) The particle that produced track XY was a π^+ . Deduce the direction of the magnetic field in the photograph.

(1)

(d) At Y, the π^+ decayed into a positively charged muon (μ^+) and a muon neutrino. The μ^+ has a very short range before decaying into various particles, including a positron which produced the final spiral.

(i) Give **two** reasons why you can deduce that the muon neutrino is neutral.

(2)

1.....
.....
.....

2.....
.....
.....

(ii) Explain the evidence from the photograph for the production of the muon neutrino at Y.

(3)

.....
.....
.....
.....
.....
.....

(Total for Question 14 = 10 marks)

15 A vinyl disc is used to store music. When the disc is played, a stylus (needle) moves along in a groove in the disc. The disc rotates and bumps in the groove cause the stylus to vibrate.

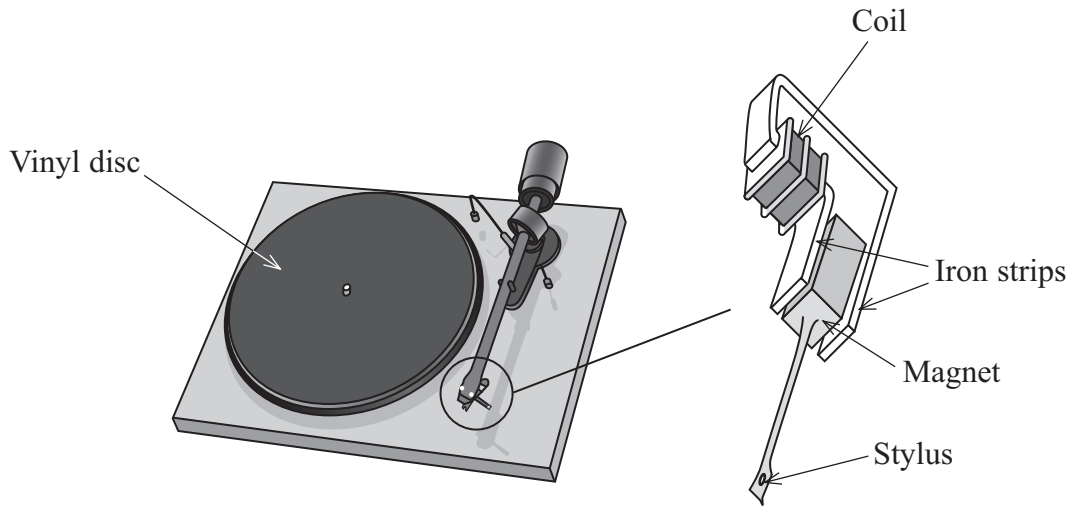

The stylus is attached to a small magnet which is near to a coil of wire. When the stylus vibrates, there is a potential difference across the terminals of the coil.

(a) Explain the origin of this potential difference.

(4)

.....

.....

.....

.....

.....

.....

.....

.....

.....

(b) The potential difference is then amplified and sent to a loudspeaker. Long-playing vinyl discs (LPs) have to be rotated at 33 rpm (revolutions per minute) so that the encoded bumps in the groove lead to the correct sound frequencies.

(i) Calculate the angular velocity of an LP.

(2)

.....

.....

.....

.....

Angular velocity =

(ii) As the stylus moves towards the centre of the LP the encoded bumps must be fitted into a shorter length of groove.

Explain why the encoding of bumps in the groove becomes more compressed as the stylus moves towards the centre.

(3)

.....

.....

.....

.....

.....

.....

.....

(Total for Question 15 = 9 marks)

16 The diagram shows a circuit that includes a capacitor.

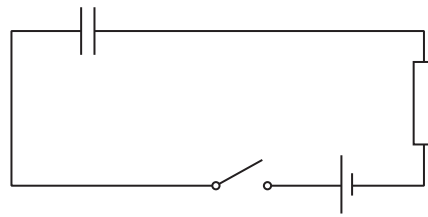

(a) (i) Explain what happens to the capacitor when the switch is closed.

(2)

.....

.....

.....

.....

(ii) The potential difference (p.d.) across the resistor rises to a maximum as the switch is closed.

Explain why this p.d. subsequently decreases to zero.

(2)

.....

.....

.....

.....

***(b)** One type of microphone uses a capacitor. The capacitor consists of a flexible front plate (diaphragm) and a fixed back plate. The output signal is the potential difference across the resistor.

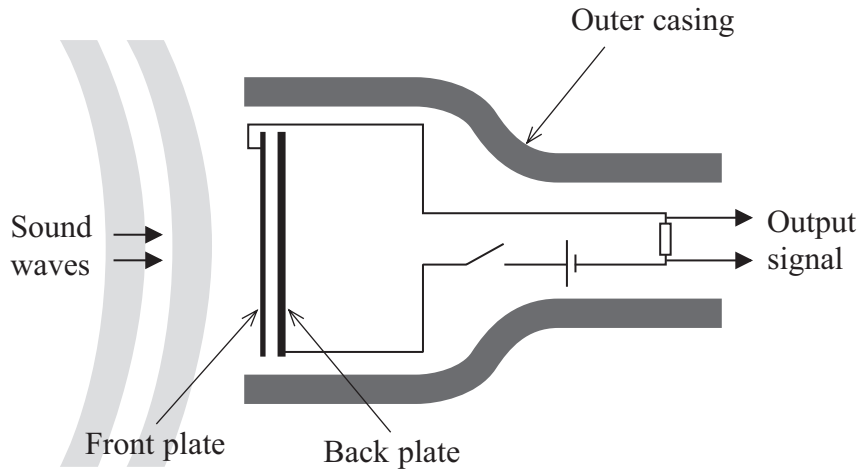

The sound waves cause the flexible front plate to vibrate and change the capacitance. Moving the plates closer together increases the capacitance. Moving the plates further apart decreases the capacitance.

Explain how the sound wave produces an alternating output signal.

(4)

.....

.....

.....

.....

.....

.....

.....

.....

.....

.....

.....

.....

.....

.....

.....

.....

.....

.....

.....

.....

.....

.....

.....

(c) A microphone has a capacitor of capacitance 500 pF and resistor of resistance 10 MΩ.

Explain why these values are suitable even for sounds of the lowest audible frequency of about 20 Hz.

(4)

.....

.....

.....

.....

.....

.....

.....

.....

.....

.....

.....

.....

.....

.....

.....

.....

.....

.....

.....

.....

.....

.....

(Total for Question 16 = 12 marks)

17 Anti-hydrogen atoms have been created at CERN. An anti-hydrogen atom consists of an anti-proton and a positron.

(a) Compare the properties of an anti-hydrogen atom with a hydrogen atom.

(2)

.....

.....

.....

.....

(b) Calculate the electrostatic force of attraction between the positron and the anti-proton.

Assume that the radius of the anti-hydrogen atom is 5.3×10^{-11} m.

(3)

.....

.....

.....

.....

.....

.....

.....

.....

Force =

- (c) Scientists want to find out if anti-hydrogen atoms emit the same spectra as hydrogen atoms. Anti-protons are relatively easy to contain, however, it is very difficult to contain anti-hydrogen atoms for any period of time.

Explain why it is difficult to contain anti-hydrogen atoms compared with anti-protons.

(2)

.....

.....

.....

.....

- (d) The technology suggested in the science fiction series, Star Trek, for powering the Starship Enterprise relied on antimatter. When an anti-hydrogen atom meets a hydrogen atom, they annihilate and produce energy.

- (i) How much energy, in joules, would be produced by the annihilation of just 1 milligram of anti-hydrogen atoms?

(3)

.....

.....

.....

.....

.....

.....

Energy =J

- (ii) Anti-protons are required to produce anti-hydrogen atoms. The total production of anti-protons on Earth over the past 25 years adds up to only a few nanograms.

Suggest why so little anti-matter has been created.

(1)

.....

.....

(Total for Question 17 = 11 marks)

18 James Chadwick is credited with “discovering” the neutron in 1932.

Beryllium was bombarded with alpha particles, knocking neutrons out of the beryllium atoms. Chadwick placed various targets between the beryllium and a detector. Hydrogen and nitrogen atoms were knocked out of the targets by the neutrons and the kinetic energies of these atoms were measured by the detector.

(a) The maximum energy of a nitrogen atom was found to be 1.2 MeV.

Show that the maximum velocity of the atom is about $4 \times 10^6 \text{ m s}^{-1}$.

mass of nitrogen atom = $14u$, where $u = 1.66 \times 10^{-27} \text{ kg}$

(3)

.....

.....

.....

.....

.....

.....

(b) The mass of a neutron is Nu (where N is the relative mass of the neutron) and its initial velocity is x . The nitrogen atom, mass $14u$, is initially stationary and is then knocked out of the target with a velocity, y , by a collision with a neutron.

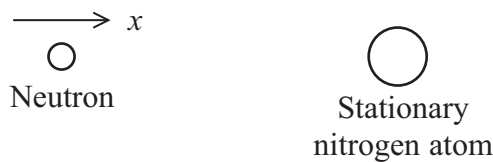

(i) Show that the velocity, z , of the neutron after the collision can be written as

$$z = \frac{Nx - 14y}{N}$$

(3)

.....

.....

.....

.....

.....

.....

(ii) The collision between this neutron and the nitrogen atom is elastic. What is meant by an elastic collision?

(1)

(iii) Explain why the kinetic energy E_k of the nitrogen atom is given by

$$E_k = \frac{Nu(x^2 - z^2)}{2}$$

(2)

(c) The two equations in (b) can be combined and z can be eliminated to give

$$y = \frac{2Nx}{N+14}$$

(i) The maximum velocity of hydrogen atoms knocked out by neutrons in the same experiment was $3.0 \times 10^7 \text{ m s}^{-1}$. The mass of a hydrogen atom is

$1u$. Show that the relative mass N of the neutron is 1.

(3)

(ii) This equation can **not** be applied to all collisions in this experiment.

Suggest why.

(1)

(Total for Question 18 = 13 marks)

TOTAL FOR SECTION B = 70 MARKS

TOTAL FOR PAPER = 80 MARKS